

DAVR-40

USER MANUAL

INSTALLATION AND COMMISSIONING

Table of Contents

Revision history:.....	4
1- Product Description:	5
1.1 Product marking:	1
2- Technical Specifications:	2
2.1 General Features:	3
2.2 Mechanical Dimensions:	4
2.3 Mounting:.....	5
3- Installation:.....	6
3.1: Definition of Terminals & Indicators:.....	6
3.1.1: Terminal connections and cable sizes:.....	6
3.2: System Block Diagram:.....	7
3.3: Power Connection Terminals:	8
3.3.1: Alternator Voltage Sensing:	8
3.3.2: Current Sense (CT) connection:.....	9
3.3.3: Power Supply and FIELD winding connections:	10
3.3.4: Connection with high-voltage transformer:.....	14
3.4: “Auxiliary & Communication Terminals” connections:.....	15
3.4.1: Temperature Sensor connections:.....	15
3.4.2: Analogue Signal connections:	15
3.4.3: External Pot connection:	16
3.4.4: RELAY contact terminals:.....	16
3.4.5: Communication Port Connection:.....	17
3.5: Trimmers and Indicators:.....	17
4- Voltage Regulation:	18
4.1: AVR Voltage Sensing configuration:	18
4-2. AVR “Voltage Range Selection” and VLT Pot setting:.....	18
4.3: Setting the CT ratio on AVR unit:	19
4-4. External Pot connection (E1 & E2 terminals):.....	20
4-5. AUXILIARY Analogue Signal connections:	21
5- PID Parameters Settings (Stability control):	24
5.1: Understanding DAVR40 Dynamic Behaviour:.....	24
5.2: Using “STB” trimmer on the AVR unit:	25
5.3: Definition of K_P (Differential Coefficient) parameter:	25
5.4: Definition of K_I (Integral Coefficient) parameter:	25
5.5: Definition of K_D (Differential Coefficient) parameter:.....	26
5.6: Steady State Voltage Regulation:	26
5.7 Reference Change “Ramp Limit” function:.....	27
5.8: Dynamic behaviour of AVR based on PID settings:	27
5.9: Management of set PID parameters:	28

6- "Load Acceptance" Parameter Settings:.....	29
6.1: Setting UFRO parameters:.....	29
6.2: Setting "Load Acceptance" parameters (LAM):.....	30
6.2.1: Setting DWELL parameters:.....	31
6.2.2: Setting Minimum Voltage Reference Percentage:	32
7- "Droop" Parameter Settings:.....	33
7.1: "Droop" Phase Compensation:	34
8- AVR "START SEQUENCE" Control:.....	35
8.1: "Starting Frequency" Delay function:	36
8.2: "Start Time Delay" Function:	37
8.3: "Soft Start Ramp" Function:	37
8.4: "Auto-Start" Enable/Disable:	38
8.5: "External Start/Stop" Control function:	38
8.6: Manual "Start Control" with parameter setting:	39
9-Configuration of AUXILIARY Inputs:.....	40
10- "Field Winding" connection (Alternator EXCITATION):.....	41
10.1 FIELD drive current:	42
10.1.1: "Safe-Operating-Area" (SOA) curve of Excitation Output:	43
10.1.2: POWER limitation of Excitation Output:.....	43
10.1.3: IDMT curve Protection for Excitation:	44
10.2 Fuse protection:	45
11- Setting the Protection functions on DAVR40:	46
11.1: "OEX Protection" function:.....	46
11.2: Loss-Of-Sense (LOS) protection function:	48
11.3: Generator Over Voltage (GOV) protection function:	49
11.4: Generator Under Voltage (GUV) protection function:	50
11.5: Stator Voltage Unbalance (SVU) Protection:	51
11.6: Generator Current Limit (GCL) protection Function:.....	52
11.7: Winding Temperature Alarm (WTA) function:	53
11.8: Winding Temperature Limit (WTL) protection function:	54
11.9: Alternator "Short Circuit" Threshold:.....	56
11.10: Setting the RELAY operation mode:.....	57
11.11: Alarm FLAGS and Alarm output RESET:.....	57
11.12: Alarm LED Indication:.....	57
11.13: Resetting parameter settings:	58
11.14: Reset internal engine hours meter:	58
12- Communication ports:.....	58
12.1: Connection to USB port:	59
12.2: Firmware ID registers:.....	59
13- Application Diagrams:.....	60



13.1: DAVR40 installation with 3-phase sensing and AUX winding: 60

13.2 DAVR40 installation with SHUNT configuration: 61

14- DAVR40 Parameter List: 62

14.1: "Read-Only" Parameters: 62

14.2: "Settable" Parameters List: 64

15- Basic Trouble shooting steps:..... 68

15.1 AVR is connected and there is no voltage at the alternator output: 68

15.2 Voltage is generated but voltage reading is not correct: 68

15.3 Voltage stability issues: 69

DAVR-40

(Digital Automatic Voltage Regulators for Synchronous Alternators)

1- Product Description:

DAVR40: Advanced Digital Voltage Regulation

The DAVR40 is a **state-of-the-art microcontroller-based design** that converts all analogue input signals into digital data for **high-speed processing**. This digital signal processing enables precise mathematical transfer function analysis, resulting in superior performance compared to traditional analogue AVR units.

With its **digital control architecture**, the DAVR40 regulates alternator voltage using **precise RMS calculations**, incorporating multiple harmonics of the fundamental power signal frequency. This ensures **exceptional voltage regulation**, even under high harmonic load conditions, where analogue AVRs typically struggle to maintain stability.

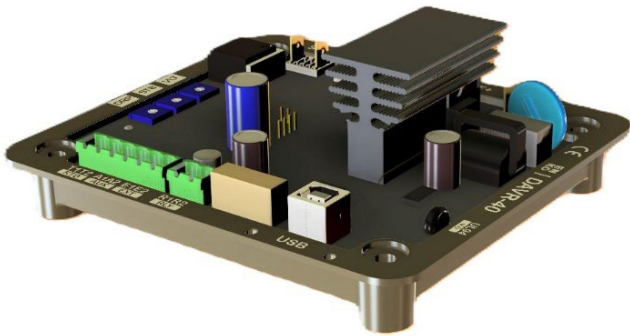

The DAVR40 features **True Over-Excitation Protection**, independent of the alternator field impedance. Its integrated **Inverse Definite Minimum Time (IDMT) function** continuously monitors the field winding load, preventing heat accumulation and thermal runaway in cases of intermittent high-load applications. This ensures reliable protection against alternator malfunctions. Additional built-in protection mechanisms are detailed further in this manual.

For **parallel-connected applications**, the DAVR40 precisely regulates **reactive load current**, providing

stable reactive load sharing between multiple generators under all operating conditions.

All AVR parameters can be fully configured by the user before operation. The **on-board USB port** enables direct connection to the AVR for viewing and configuring parameters via a PC without requiring an external power source. This feature is particularly beneficial during **system commissioning and generator tuning** to meet specific customer requirements.

The **AUX input terminals** can be programmed based on application needs. For details on assigning special functions to this input, refer to the **AUX Terminal Configuration Settings** section of this manual.

Designed and manufactured to the highest standards, the DAVR40 ensures **safe and reliable operation**. All components are sourced from **Approved Original Component Manufacturers**, guaranteeing **traceable quality standards**.

Its **robust plastic tray construction** allows easy and secure mounting on the alternator. The unit can be installed directly onto a **metal panel surface** or mounted on **anti-vibration (AVM) rubber suspensions** for enhanced vibration protection. Additionally, the AVR is encapsulated in **UL-approved polyurethane material**, ensuring high resistance to harsh environmental conditions and offering a superior RTI level.

For detailed **technical specifications**, refer to the table below. Wiring harness design information can be found in the installation configuration sections of this manual.

Since DAVR40 is a **fully programmable unit**, users should refer to the **PC-Configuration Tool manual** to customize AVR parameters according to their specific needs. Before operation, check the factory default parameter list to ensure compatibility with your application. If adjustments are required, the **PC-Configuration Tool** can be used to modify parameter values accordingly.

1.1 Product marking:

DAVR40 is part of a family of “Digital Automatic Voltage Regulators”, designed and manufactured by ENKO and each version may have one or more options, and these options are defined in the device marking and ordering code form.

To get more detailed information on the optional features of DAVR40, visit www.enkoelektronik.com web site or contact your local dealer.

Product name and model number, including all the terminal identifications are printed on the plastic tray side plates. For on-line technical specifications and user manual information, scan the QR code on the back side of the AVR unit. Getting the product information from on-line ensures latest updated information is received.

During installation, general safety measures must be taken, and all wiring must be made according to high-voltage installation standards.

Only professional technicians must attempt to install these devices. Damage to the device and/or to person can occur, if not installed properly.

Where required, WARNING boxes are used in this manual.

	<i>WARNING MESSAGE</i>
--	------------------------

These warning boxes inform the user for critical precautions to be taken during installation and commissioning the AVR units for safe and reliable operation. Please follow the instructions given in this manual and where in doubt, please contact www.enkoelektronik.com for further assistance in your applications.

enclosure. If the AVR is going to be located elsewhere, additional shielding is required. In some more demanding applications, additional EMC filters are required. In this case, please contact ENKO sales team for additional EMC accessories required to meet the regulations. More information is available for additional EMC filtering accessories, which can be supplied directly from ENKO.

These devices comply to CE regulations for EMC radiation and immunity and UL94 for flammability and safety requirements. These conditions are only valid if the AVR is mounted directly on the alternator metal

If products are printed with a QR code, user can scan the code for detailed installation information and technical specifications for the AVR unit.

	The AVR units are subject to hazardous voltages during operation. Special care must be taken when handling the AVR units mounted on the alternator. DO NOT contact the AVR units when the generator is running. Always switch off the generator before servicing the AVR unit.
---	--

	Heatsink on the AVR unit may reach high temperatures, therefore, take necessary precaution before touching the heatsink surface during servicing. Damage may occur to human skin, if touched when the heatsink surface is hot.
---	--

2- Technical Specifications:

Parameter	Value	Conditions
Operating temperature range:	-40°C to +60°C	At full specified rating
Excitation Derating:	+60°C < -5%/°C < +70°C	50% POWER derating at 70°C (700W max.)
Storage temperature range:	-40°C to +85°C	No direct exposure to radiant heat source
Sense voltage:	100Vac – 480Vac (576Vac max. phase-phase)	3-phase sensing, 2-phase sensing, phase-neutral sensing, software configurable,
Voltage sensing type:	TRUE rms reading	High-resolution waveform sampling & sensing
Operating frequency:	25Hz to 75Hz	Configurable operating frequency selection
Voltage adjustment:	On-board trimmer	±15% of selected range (set by parameter)
	External pot	±10% of on-board trimmer set voltage (set by parameter)
	Aux. input	±15% of set voltage (set by parameter)
Current sensing:	1-phase, X/1A class-1	CT connection on “Generator V phase” only
	1-phase, X/5A class-1	
Current overload:	300% of rated value	
Current sensing operation mode:	Droop compensation	Set by configuration software parameters
	Line drop compensation	
CT load burden:	1VA	3VA maximum
Power input to AVR:	Shunt power connection	300Vac max.
	Auxiliary power connection	
Excitation current:	5.0A dc max.	Continuous rating, 600W maximum
	7.0A dc max.	20 sec. max.
	10.0A dc max.	10 sec. max.
Field impedance range:	15Ω nominal value	5Ω to 50Ω
Field drive:	SCR controlled	Half-wave rectified configuration
Voltage regulation:	≤0.5% of set value	<4% of frequency change
	True RMS reading	Regulation to True RMS value
Dynamic response time:	<300ms	<60% block load change
AUX control input:	External pot input	1KΩ for voltage trimming
	External analogue input	0.5Vdc-10Vdc (linear control)
External pot detection:	Yes	Automatic detection of pot disconnection
Loss-of-sense protection:	Yes	Monitor and shut down after set time delay
OEX protection:	Yes	Software setting according to excitation data, IDMT protection function,
UFRO setting:	0-10% of nominal set frequency	Software settable knee-point frequency
Dynamic LAM function:	-V/Hz slope setting	0%Ur/Hz to -15%Ur/Hz User settable parameter according to required performance
VOLTAGE setting:	±20% of selected range	S/W parameter setting for range, Set with on-board trimming pot
STABILITY setting:	Fine tuning of PID values	
DROOP setting:	-20% to +20% reactive load droop setting	
External pot setting range:	±10% of set voltage value	
AUX input trimming:	±10% of input signal	
Indicators:	Single RGB LED	Multifunction indication
Alarm Log:	64 alarm logs register,	FIFO arrangement, viewing with “PCTools” software,
Assembly:	Encapsulated in single plastic tray	Suitable for vertical and horizontal mounting
Weight:	220gr	
Dimensions:	142mm x 127mm x 58mm	Plastic enclosure with printed labels
Conformity to standards:	EN61000-6-2	Immunity
	EN60068-6-4	EMC Emissions
	EN60068-2-1	Temperature cold test
	EN60068-2-2	Temperature dry/heat test
	EN60068-2-6	Vibration
	EN60068-2-27, 30, 78	Environmental tests



2.1 General Features:

- Voltage sensing:
 - Connection with 3-phase, 2-phase or Phase-Neutral configuration,
 - TRUE RMS voltage sensing,
- High accuracy voltage regulation:
 - Better than 0.5% regulation of set value between no-load to full-load change,
 - Capable of tight regulation with high harmonic content load conditions,
- Wide range of voltage input selection:
 - 100Vac to 480Vac sense input capability, (withstand to 600Vac)
 - Sense voltage range selection by software parameter setting,
- Shunt and auxiliary power connection for AVR power input,
- High field-current capacity:
 - 5A_{dc} continuous excitation current capacity,
 - 7A_{dc} for 20 seconds,
 - 10A_{dc} for 10 seconds,
 - Maximum continuous excitation power is 600W
- Excellent performance with high “block-load” change on the generator output:
 - Built-in LAM function,
 - Adjustable dynamic response
 - Built-in UFRO setting for frequency roll-off point adjustment,
- Load current sensing:
 - Galvanically isolated current sense input,
 - “Reactive droop” control for parallel gen-set operation,
 - “Line drop” compensation for stand-alone operation,
 - “Load Balancing” function,
 - Parameters set via PCTools software,
- Auxiliary inputs:
 - External voltage trimming pot connection input,
 - Analogue voltage control input for external device interface,
 - On-board auxiliary input trimming pot,
- Adaptive stability control:
 - On-board stability setting pot,
 - Adaptive stability control for different alternator frame sizes,
- Built-in protection:
 - “OEX” (Over Excitation) protection with latch shut-down feature (customised according to alternator FIELD winding impedance, factory setting only, not enabled)
 - “Loss of Voltage Sensing” protection with 3-phase operation and single-phase connection,
- Robust construction:
 - Built into non-flammable plastic tray for easy mount on the alternator or in the electric cabin,
 - Encapsulated against harsh environmental conditions,
 - UL compliant non-flammable encapsulation for maximum protection,
 - Terminal identifications printed on the plastic tray,
- LED indicator:
 - On-board LED indicator for warnings and status indication
 - RGB LED for easy status identification,
- Conformity to standards:
 - CE safety for emissions and immunity,
 - UL94 non-flammability,
- Mechanical dimensions:
 - Width: 127mm
 - Length: 142mm
 - Height: 51.0mm

2.2 Mechanical Dimensions:

Mechanical dimensions of DAVR40 are shown in the drawing below:

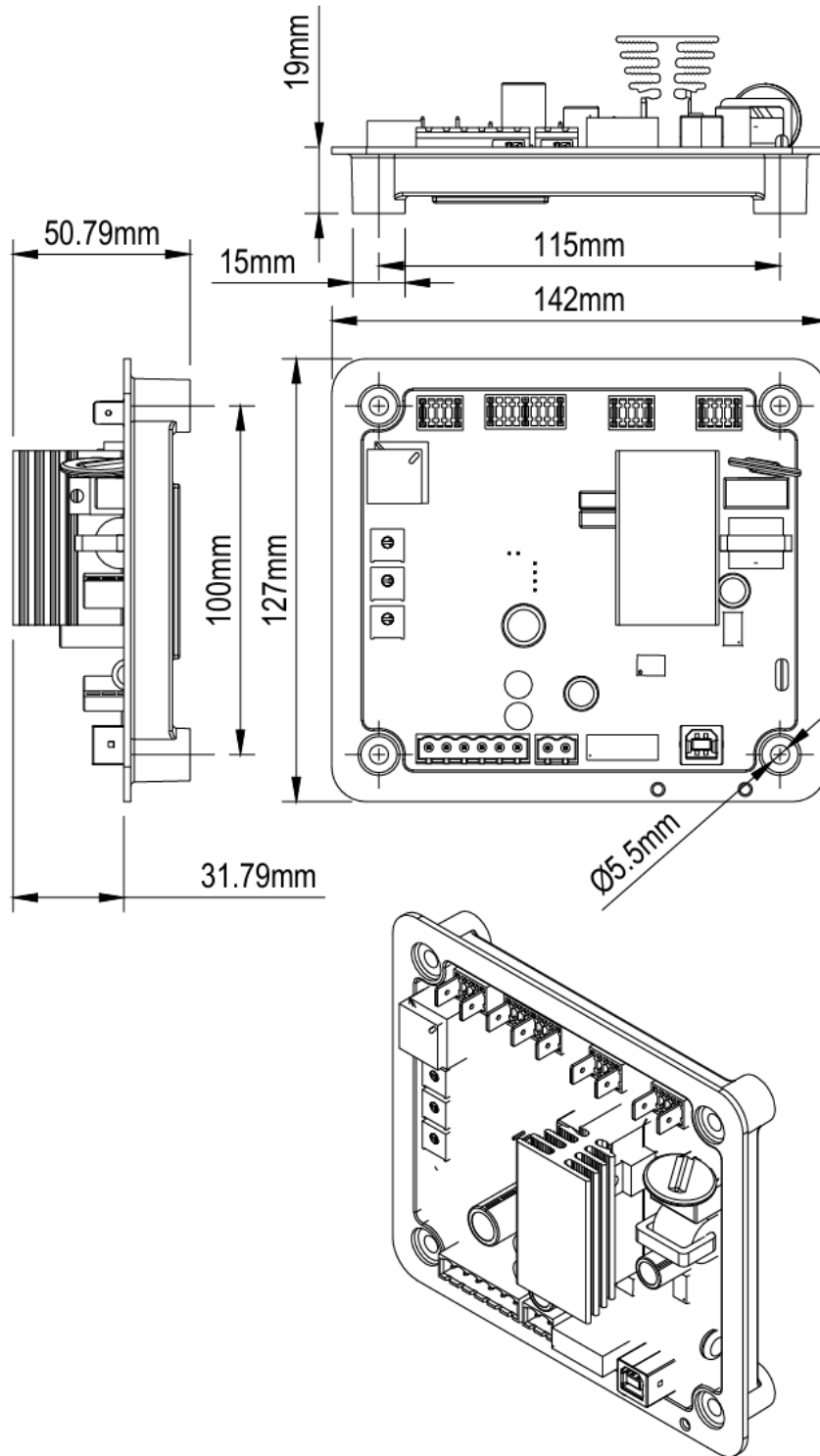

2.3 Mounting:

Mechanical mounting of DAVR40 is shown in figure below. These AVR units are designed for RIGID mounting but for very high vibration applications, it is recommended that; rubber “Anti Vibration Mount” (AVM) fittings are used between the AVR body and the mounting plate.

If the AVR is mounted onto a metal plate with rigid mounting technique, ensure that locking-nut is used to avoid loosening of the nuts due to engine vibration in the long-term use.



Do not exceed the tightening torque limit when mounting the AVR unit. Recommended torque is 3Nm (5Nm max). Use torque-controlled tools to ensure correct tightening force. Failing to do so may cause the AVR plastic case to crack and AVR may not operate properly.

Ensure that; the plate surface is flat before mounting the AVR unit. Mounting onto a rigid surface with uneven surface geometry will damage the sensitive components inside the AVR unit. Refer to figure below for mounting:

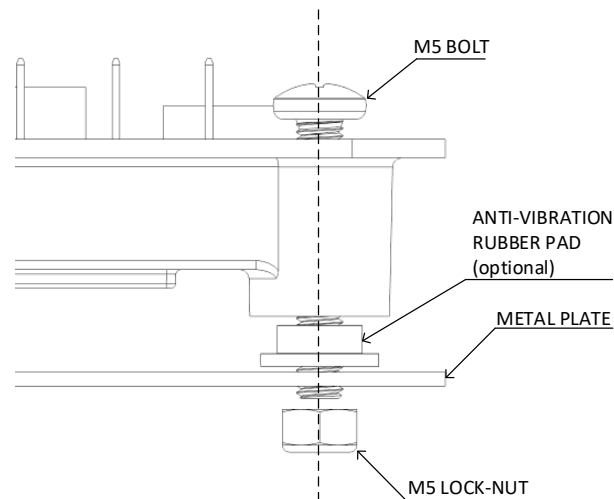

Mounting and Installation Guidelines for the AVR Unit

Different types of **anti-vibration rubber mounts** can be used based on application requirements. Ensure that the **bolt length** is appropriate, considering the combined thickness of the mounting plate and rubber mount (if used). Before operation, confirm that **all four mounting holes** of the AVR unit are securely fixed to the plate.

The **standard mounting position** for the AVR is **vertical**. If necessary, the AVR can also be installed **horizontally**. However, **do not** mount the AVR with the heatsink facing downward, as this will negatively impact its operating temperature range. Additionally, avoid placing the AVR in **sealed small cavities**—instead, choose a **ventilated location** to circulate the heat generated by the unit effectively.

When connecting the **cable harness**, ensure that no cables come into contact with the **heatsink**. Prevent cable clutter over the AVR unit, and make sure that harnesses for the **top and bottom terminal rows** are routed directly away from the AVR without crossing over it.

The **AVR heatsink is "potential-free"** and electrically isolated from the live components of the unit. However, **all AVR terminals are LIVE** and may carry hazardous voltage levels relative to **EARTH**. Exercise caution when handling the unit to prevent electrical hazards.

3- Installation:

DAVR40 can be installed either in the generator control cabinet or on the alternator. For wiring of the AVR unit, please refer to this manual at every step and ensure correct wiring of the terminals, based on the wiring of alternator stator winding configuration. If further information is needed during installation, contact authorised service or get in touch with sales@enkoelektronik.com

3.1: Definition of Terminals & Indicators:

DAVR40 is equipped with terminals, trimmers, and indicators to fulfil the interface of the AVR unit with the alternator. The terminals are grouped according to their functions, and these are shown in the figure below:

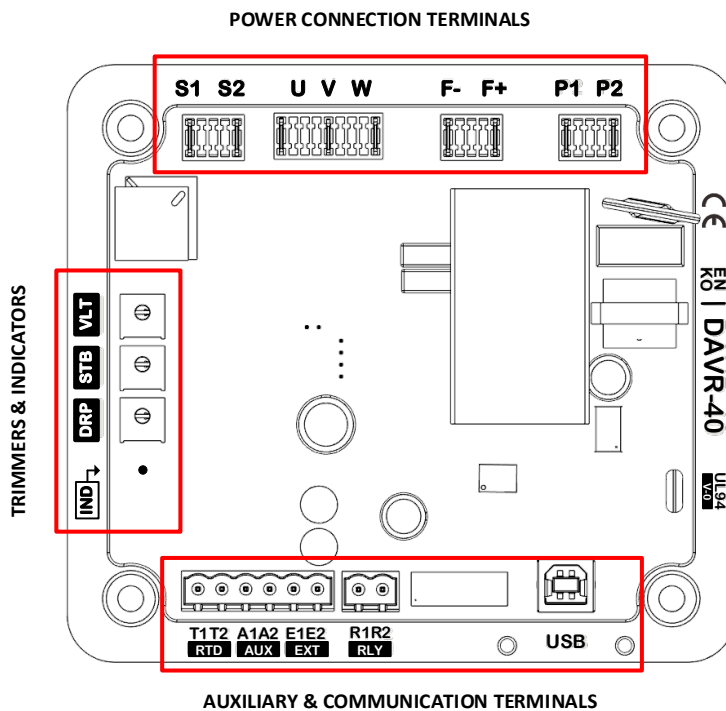

1. Power connection terminals group (fast-on terminal connections)
2. Auxiliary & Communication terminals group (screw type terminal connections)
3. Trimmers and Indicators group

3.1.1: Terminal connections and cable sizes:

Terminal cable sizes:			
Terminals:	AWG	Diameter (mm)	Area (mm ²)
S1, S2, U, V, W	15	1.42	1.5
F-, F+, P1, P2	13	1.82	2.5
T1, T2, A1, A2, E1, E2, R1, R2	17	1.15	1.0
USB	Use USB Type-B cable with moulded terminal only		

3.2: System Block Diagram:

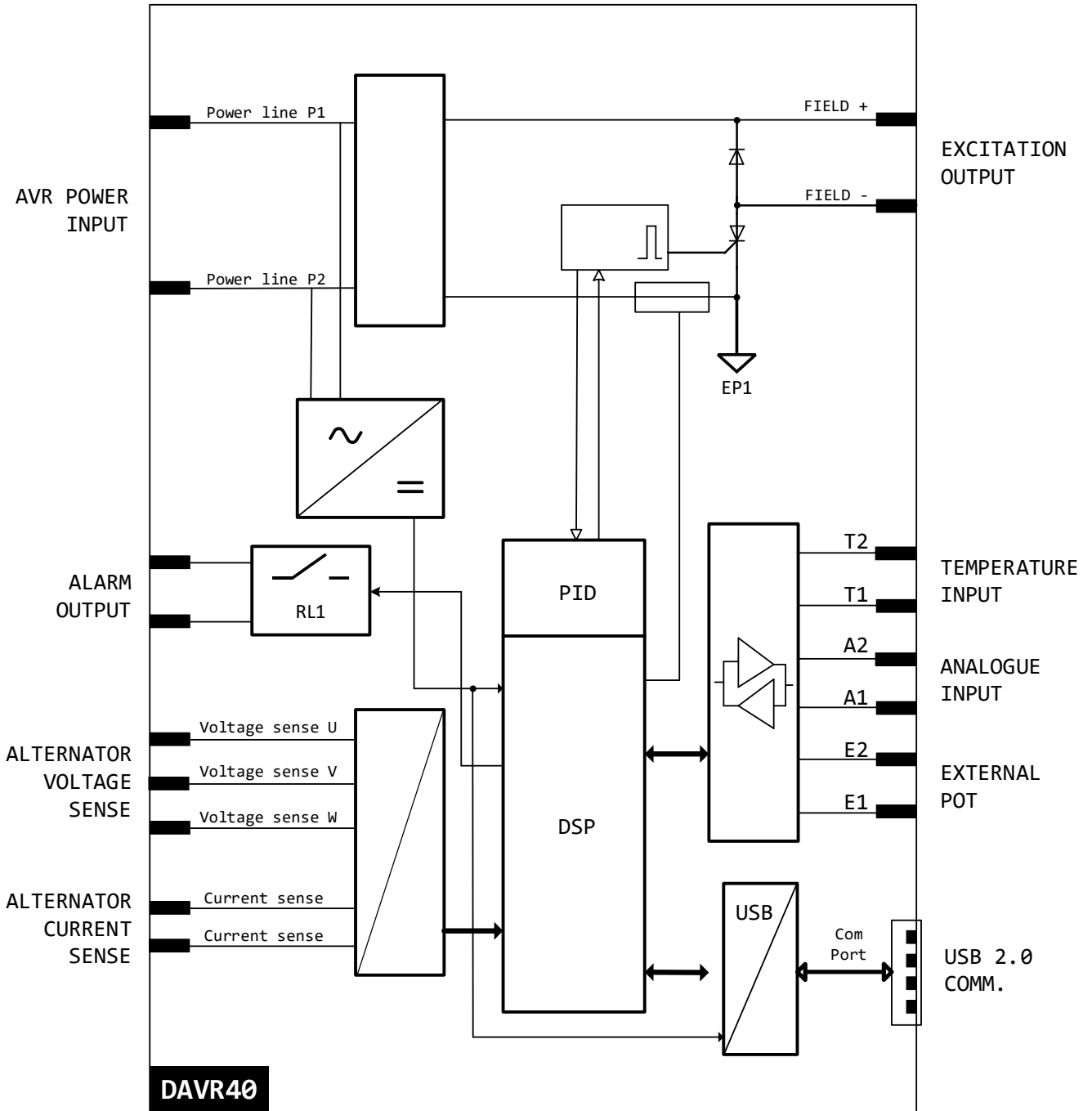

3.3: Power Connection Terminals:

Power signal connections to the AVR are grouped on the top side of the AVR unit and they are arranged as “Fast-on” connection terminals. All the cable ends must be fitted and crimped with appropriate fast-on terminals with proper insulation sleeves.

	<p>All “POWER CONNECTION” cables to the AVR MUST be fitted with proper rubber insulation sleeveings. Any connections without proper sleeveings will cause AVR unit to fail during operation.</p>
---	--

3.3.1: Alternator Voltage Sensing:

DAVR40 is 3-phase feedback sensing AVR. Voltage sensing can be arranged as 3-phase (connected across U, V and W phases of the alternator) or it can be arranged 2-phase (connected across U and W phase terminals of the AVR). If required, the DAVR40 can also be connected in “Phase-Neutral” sense configuration as shown in the connections table below. Terminal arrangement is shown in the terminal Identification table below:

“VOLTAGE Sensing Terminals” identification:			
DAVR40 Terminal ID	Connection	Rating	Terminal group
U	Alternator “U” phase	480Vac(RMS) nominal	POWER CONNECTION TERMINALS GROUP-1
V	Alternator “V” phase		
W	Alternator “W” phase		

The voltage sensing terminals are “high impedance” inputs and can be connected in various configurations as shown in table below. Maximum voltage withstand limit of sensing terminals is limited to 480Vac +20% continuous. Therefore, when connecting the AVR unit, ensure that correct voltage sensing range is selected from the configuration S/W and the terminals are connected correctly on the alternator.

The voltage range selection parameter indicates the nominal voltage regulation reference point when the VOLTAGE ADJUST trimmer is set to its MIDDLE position on the AVR unit.

DAVR40 can only regulate the voltage at the point of its sensing terminal connections. Therefore, in the following paragraphs, voltage range selection and voltage adjust pot act with respect to the voltages seen across the sensing terminal connections. User must select the correct voltage sensing range and set the pot position according to their application requirement.

Possible voltage sensing connections for DAVR40 are shown in the tables below:

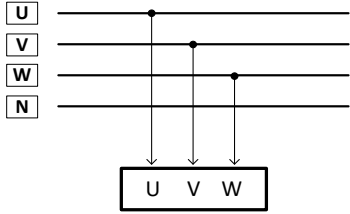
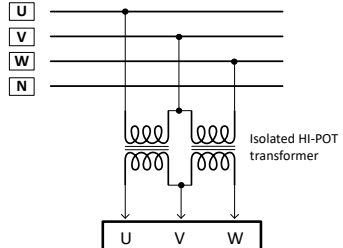
Voltage sense connections	Direct connection <i>(Either from stator main terminals or from winding mid-point connections)</i>	Hi-pot transformer connection
3-Phase Connection		

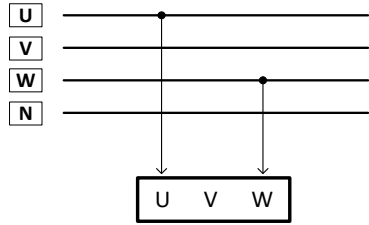
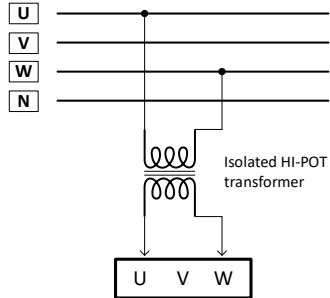
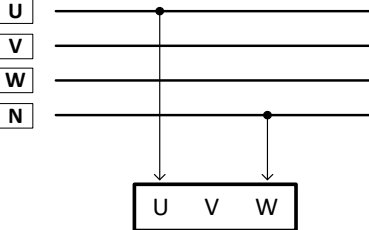
<p>2-Phase Connection</p>		
<p>Phase – Neutral connection</p>		<p>Not applicable</p>

	<p>Voltage Sense connections must match the selected voltage range of the AVR unit. Refer to the voltage range selection topic of this user manual before making connections to the alternator.</p> <p>If the AVR is connected in SHUNT mode, make sure that; the POWER SUPPLY input to the AVR is not exceeded, it is limited to 300Vac maximum (absolute maximum allowed voltage limit).</p> <p>Also, when connecting the current transformer CT, please refer to the current transformer connection information given in this manual. If CT is not connected properly, reactive droop will perform badly, and reactive load sharing will not operate.</p>
---	--

3.3.2: Current Sense (CT) connection:

Refer to the CT connection table below for various CT connection configurations for DAVR40. Current transformer terminals are labelled as S1 and S2 as shown in below illustration:

“CURRENT Sensing Terminals” identification:			
DAVR40 Terminal ID	Connection	Rating	Terminal group
S1	Alternator “V” phase	X/1 or X/5	POWER CONNECTION TERMINALS GROUP
S2			

The CT inputs; S1 and S2 are isolated and rated to 5A max. Therefore, when selecting the alternator current measurement transformer, ensure that it is rated as X/5 and accuracy is Class-1. The CT inputs of AVR is designed to withstand high current peaks, occurring

during operation. Make sure that; cables to S1 and S2 are as short as possible. If longer cable must be used, ensure that; the CT cables are shielded and grounded the alternator side.

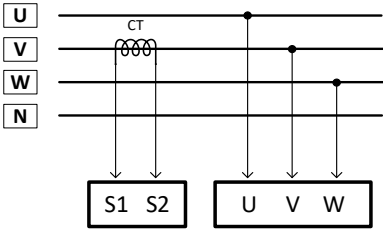
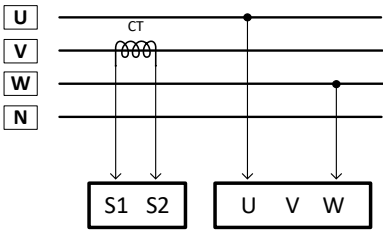
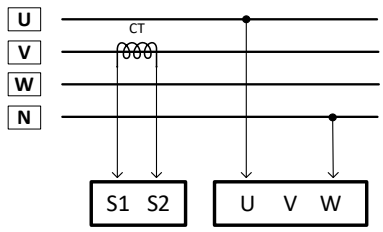
<p>CT connection with 3-phase voltage sensing (CT connected to "V" phase)</p>	
<p>CT connection with 2-phase voltage sensing (CT connected to "V" phase)</p>	
<p>CT connection with phase-neutral voltage sensing (CT connected to "V" phase, Reactive Droop is not possible in phase-neutral connection configuration mode)</p>	

NOTE:

CT connection on DAVR40 is sensitive to phase of the alternator and rotating vector direction. Therefore, user must take special care to which phase the CT is connected. On DAVR40 AVR unit, CT is always connected to the middle phase winding (phase "V") and the polarity must match the direction of phasor rotation. If droop function operates in reverse characteristic, then change the polarity of CT connection at AVR terminals S1 and S2.

Refer to the CT connection chapter of this user manual, before attempting to connect the power terminals of the AVR units.

3.3.3: Power Supply and FIELD winding connections:

Power Supply input to DAVR40 is limited to 300VAC maximum. In any application, exceeding this voltage level may damage the AVR unit. Take special care when connecting the voltage sensing input and AVR power supply input in SHUNT connection mode.

Power to AVR can be connected in "SHUNT" mode or "AUXILIARY" supply mode as required. Possible connection configurations are given in the table below for different arrangement of the alternator stator winding arrangements.

"EXCITATION and AVR POWER INPUT" Terminals identification:			
DAVR40 Terminal ID	Connection	Rating	Terminal group
F-	Excitor winding -'ve terminal	5Adc (continuous)	POWER CONNECTION TERMINALS GROUP-1
F+	Excitor winding +'ve terminal	7Adc (120 seconds)	
P1	AVR Power input connection (Shunt, AUX)	10Adc (10 seconds)	
P2		300Vac (max.) 600W (max.)	

Possible AVR sense and power connection configurations are shown in table below. In this table, high-potential transformer connection configurations are not shown. For high-potential connection with insulating transformers, please refer to the related chapter of this manual.

Configuration	WIRING SCHEMATIC WITH AUXILIARY WINDING
<p>Connection with AUXILIARY winding and “3-phase” voltage sensing, <i>(Y-Star series connection, 12 leads)</i></p>	
<p>Connection with AUXILIARY winding and “2-phase” voltage sensing, <i>(Y-Star series connection, 12 leads)</i></p>	
<p>Connection with AUXILIARY winding and “phase-neutral” voltage sensing. <i>(Y-Star series connection, 12 leads)</i> <i>(Reactive Droop not possible)</i></p>	
<p>Connection with AUXILIARY winding and “3-phase” voltage sensing. <i>(YY-Star parallel connection, 12 leads)</i></p>	

<p>Connection with AUXILIARY winding and “2-phase” voltage sensing. <i>(YY-Star parallel connection, 12 leads)</i></p>	
<p>Connection with AUXILIARY winding and “phase-neutral” voltage sensing. <i>(YY-Star parallel connection, 12 leads)</i> Reactive droop not possible</p>	

Configuration	WIRING SCHEMATIC IN SHUNT CONFIGURATION
<p>Connection with SHUNT mode and “3-phase” voltage sensing, <i>(Y-Star series connection, 12 leads)</i></p>	
<p>Connection with SHUNT mode and “2-phase” voltage sensing, <i>(Y-Star series connection, 12 leads)</i></p>	

Connection with **SHUNT** mode and “phase-neutral” voltage sensing,

(Y-Star series connection, 12 leads)

(Reactive Droop not possible)

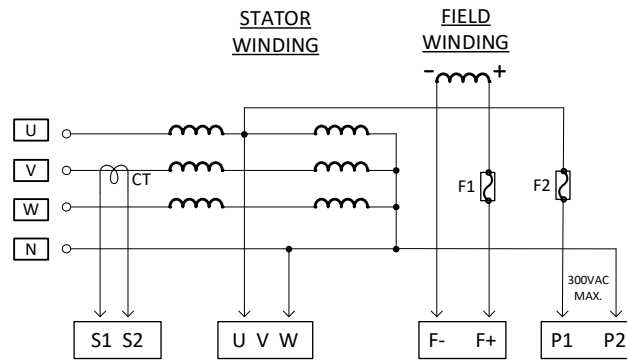

Connection with **SHUNT** winding and “3-phase” voltage sensing.

(YY-Star parallel connection, 12 leads)

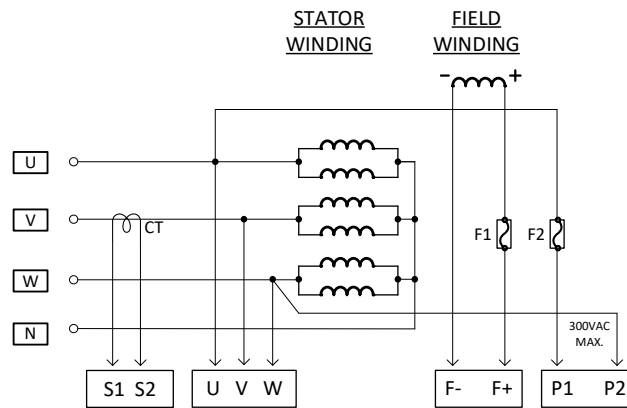

Connection with **SHUNT** mode and “2-phase” voltage sensing,

(YY-Star parallel connection, 12 leads)

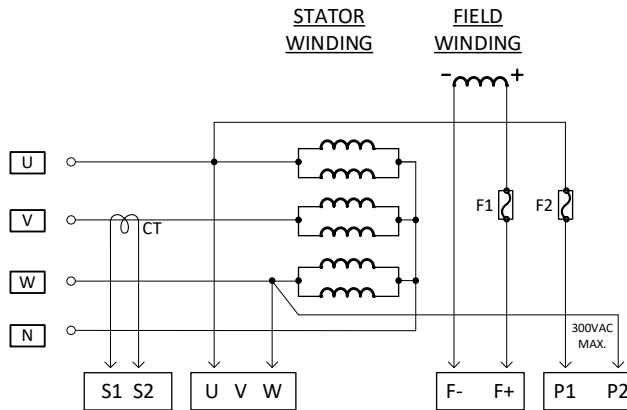

Connection with **SHUNT** mode and “phase-neutral” voltage sensing,

(YY-Star parallel connection, 12 leads)

(Reactive Droop not possible)

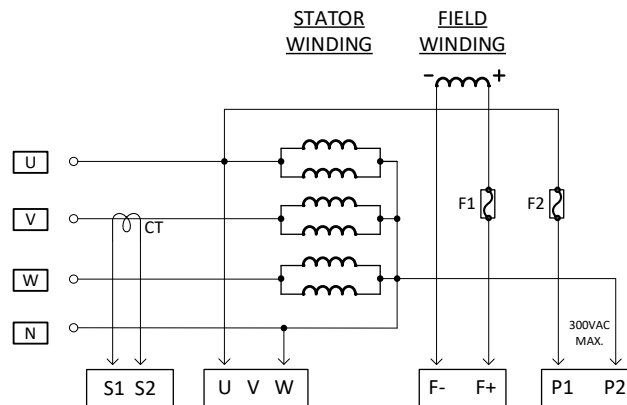



Maximum voltage across power supply terminals of DAVR40 is limited to 300Vac max. Do not exceed this limit in all applications, considering the overshoot percentage of the AUXILIARY winding, when the stator load is removed suddenly. Ensure this limit is not exceeded under all operating conditions.

Power inputs, P1 and P2 of DAVR40 is designed as “floating” connection with respect to the sense inputs and therefore can be connected across “phase-phase” terminals or “phase-neutral” terminals of the alternator, with SHUNT mode connection. Always connect P1 to “U-phase” of the alternator if wiring is in SHUNT mode. P2 can either be connected to “W-phase” or “Neutral” terminal of the alternator.

If the alternator FIELD winding impedance is $<7\Omega$ then it is better to connect P1 and P2 power supply terminals across “phase and neutral” of the stator. If FIELD impedance is $>10\Omega$ then it is better practice to connect P1 and P2 power supply terminals across phase – phase (always use the mid-point connection of each phase winding of the stator) of the alternator.

It is always a better practice to connect the power to AVR, such that a useful range of the power input can be used over the full power rating of the generator. If required FIELD power is low, then it is better to connect P1 and P2 across mid winding point and neutral line, P2 terminal being the neutral connection.

3.3.4: Connection with high-voltage transformer:

If the application is for high-voltage stator winding, then it is mandatory to use an isolation “step-down” voltage transformer between the stator windings and sense voltage terminals of the AVR unit. In this case, sensing voltage selection of the AVR unit and transformer secondary voltage must match.

Since DAVR40 can be connected either in 3-phase or 2-phase sensing configuration, hi-pot isolation transformer must be connected according to the selected sensing configuration. Use configuration software to select the correct voltage rating for regulation across the transformer secondary terminals, which should be connected directly to U-W sensing terminals of the AVR unit. Keep in mind that, AVR will regulate the voltage across its sense input terminals and set the sensing voltage parameter accordingly.

In SHUNT mode connection with isolation transformer, if same transformer is used for both sense and power supply, limited impedance of the transformer will degrade the voltage sensing signals, when maximum field load is reached. Unless the transformer power rating is calculated for ohmic voltage drop, it is a better practice to use different transformers for sensing and power supply inputs to the AVR or use AUXILIARY winding connection to power the AVR unit.



When connecting high-voltage transformers for AVR sensing, ensure that, correct phase selection is made with respect to the current measurement transformer (CT) of the alternator, else reactive load sharing will perform badly. Refer to the related information given in this user manual.

In any case, do not exceed the limits of the power supply input terminals P1 and P2 as well as the sensing terminals of the AVR unit. Make sure that; correct voltage sensing range is selected on the AVR unit and isolation high-voltage transformer secondary voltage specifications also match the selected voltage sensing range of the AVR unit.

3.4: “Auxiliary & Communication Terminals” connections:

AUXILIARY signal connections and COMMUNICATION port connections are placed on the bottom side of the AVR unit. These signal terminal connections are arranged as “screw” type connections and care must be taken when preparing the cable ends for these terminals.

	<p>Do NOT strip the cable ends more than the depth of the screw-terminal insert hole. Failing to do so may cause momentary or permanent short circuit between adjacent cable connections, which may cause the AVR to malfunction during operation.</p>
---	--

3.4.1: Temperature Sensor connections:

DAVR40 unit is fitted with a “Temperature Sensor” input such that, any winding temperature on the alternator can be measured and set to protect the alternator from “overload” or “overheat” conditions. Type of sensors and their respective settings can be examined in more detail under the related topic of this manual.

The sensor inputs are defined in the table below:

“TEMPERATURE SENSOR” input terminals identification:			
DAVR40 Terminal ID	Connection	Rating	Terminal Group
T1	Screw type terminal with AWG17 or AWG18 cable size	Pt100 (2-wire) Or “Digital Input”	“AUXILIARY & COMMUNICATIONS” Terminal group-3
T2			

	<p>T1-T2 Temperature sensor inputs are NOT galvanically isolated with respect to AUX inputs. Therefore, appropriate temperature sensors and mounting methods must be used to make sure that DAVR40 operates safely under all operating conditions.</p>
---	--

3.4.2: Analogue Signal connections:

DAVR40 has on-board “Analogue Signal” connection inputs for interfacing with external peripheral devices to control AVR behaviour under specific operating conditions. Analogue signal inputs terminals are identified as A1 and A2 and can accept both voltage and current signals. For more detailed information, please refer to the related topic in this user manual

Terminal identification and ratings are shown in the table below:

“ANALOGUE” signal input terminals identification:			
DAVR40 Terminal ID	Connection	Rating	Terminal group
A1	Screw type terminal with AWG17 or AWG18 cable size	0-10Vdc ±5Vdc 4-20mA	“AUXILIARY & COMMUNICATIONS” Terminals group-3
A2			



A1-A2 Analogue Signal inputs are NOT galvanically isolated. Therefore, when connecting analogue signals to the AVR unit, user MUST take appropriate precautions to ensure that AVR can operate safely under all operating conditions.

3.4.3: External Pot connection:

DAVR40 has “External Potentiometer” connection terminals to set the AVR voltage regulation reference value within the limits, set by the configuration parameters. For more detailed application information please refer to the related chapter of the user manual.

Terminal identification and ratings are shown in the table below:

“EXTERNAL POT” terminals identification:			
DAVR40 Terminal ID	Connection	Rating	Terminal group
E1	Screw type terminal with AWG17 or AWG18 cable size	1K Ω /1W Potentiometer (two-wire configuration)	“AUXILIARY & COMMUNICATIONS” connection terminals group
E2			



E1-E2 External Potentiometer inputs are NOT galvanically isolated with respect to the AUX terminals. Precautions MUST be taken to ensure proper operation of AVR under all operating conditions.

3.4.4: RELAY contact terminals:

DAVR40 is fitted with and ALARM relay for interfacing with external protection accessories.

“EXTERNAL POT” terminals identification:			
DAVR40 Terminal ID	Connection	Rating	Terminal group
R1	Screw type terminal with AWG17 or AWG18 cable size	SPST, N/O contacts 1A/30Vdc contact rating	“AUXILIARY & COMMUNICATIONS” connection terminals group
R2			

Relay output terminals are arranged as N/O contacts and can be configured by the configuration software. Relay contacts are dry-contact type and not connected to any potential internally. Isolation voltage rating of the relay must be observed carefully, if the contacts are going to be connected to different power sources.

3.4.5: Communication Port Connection:

DAVR40 is fitted with a USB Type-B communication port socket for device configuration. This port is “Galvanically Isolated” and can be connected to PC during device configuration. Since the port is galvanically isolated, it is possible to monitor AVR performance while the AVR is live on the alternator.

Terminal identification is shown in the table below:

“USB” Communication port identification:			
DAVR40 Terminal ID	Connection	Rating	Terminal group
USB	Type-B USB cable connection	Galvanically isolated for 500Vac	“AUXILIARY & COMMUNICATIONS” connection terminals group

	Galvanic Isolation of the AVR is provided against the sense and power connection side of the AVR. Therefore, USB port and Analogue AUX terminal signals are connected to the same power supply, which is galvanically isolated from the sensing and power connection of the alternator. Isolation is 500Vac, if higher isolation levels required, please contact the AVR manufacturer.
---	--

3.5: Trimmers and Indicators:

DAVR40 unit has integrated trimmers on board to manually set critical parameter values if necessary during commissioning. Onboard trimmers are shown in the table below:

On-board Trimmers & Indicators:			
DAVR40 Trimmers ID	Connection	Rating	Terminal group
VLT	VOLTS trimmer	±20% of set parameter value	“TRIMMERS & INDICATORS” group-2
STB	STABILITY trimmer	K _p setting of PID parameters	
DRP	DROOP trimmer	±10% of set value	

There is also a STATUS indicator LED integrated with the AVR unit. This indicator signals the current status of the AVR during operation. It is an RGB LED, and the status indication is coded with colour and intermittent operations of the LED. For more detailed information about the LED indicator signals, please refer to the related chapter in this user manual.

The warning LED signal code is given below:

- GREEN: for NORMAL operation
- RED: for ALARM and UFRO
- BLUE: flashing for USB communication

4- Voltage Regulation:

DAVR40 regulates the voltage seen across its “VOLTAGE SENSING” terminals, U, V and W phase connections of the alternator STATOR windings. Since the AVR is designed to regulate the voltage across its sensing terminals U, V and W, user MUST select the correct voltage sensing range using PC-Tools configuration software (please refer to PC-Tools configuration software section of this manual) according to the stator wiring configuration.

There are several different methods to set the regulation voltage reference on the AVR unit:

1. Using “PC-Tool” Configuration Software,
2. VLT trimmer pot position on the AVR unit, (configured with “PC-Tool” S/W),
3. EXTERNAL POT connection on the AUX terminals,
4. ANALOGUE signal input connection at the AUX terminals,

4.1: AVR Voltage Sensing configuration:

As described in the “AVR Wiring Schematic Configuration” tables above, voltage sensing of the AVR can be arranged either as “Y-Star Series Connection” or “YY-Star Parallel Connection” and based on the wiring configuration, user must select the “Voltage Sense Rating” of the wiring configuration for the AVR unit.

“Sensing Mode Configuration” is set by parameter [P122] according to the table below:

Parameter number	Parameter Description	Units	Parameter Settings	Explanations
[P122]	Alternator Stator Phase wiring configuration selection	Configuration	1, 2, 4,	U-V, V-W, WU configuration (2-phase or Phase-Neutral connection)
			7	U - V - W configuration (3-phase connection)

If [P122] = 4 and the AVR is connected as “Phase-Neutral” configuration, then the Neutral line should be connected to the “W” terminal of the AVR, as shown in the wiring configuration tables above. In all configuration settings, CT must be connected to “V” phase of the stator in the correct polarity.

4-2. AVR “Voltage Range Selection” and VLT Pot setting:

Onboard VLT pot allows the user to set the alternator voltage during operation. Nominal voltage regulation set point value of the VLT pot can be set by software configuration parameter [P100]. The VLT pot voltage setting range is selected with parameter [P139] as a percentage of the parameter value of [P100] over full VLT pot adjustment range.

Parameter number	Parameter Description	Units	Parameter Set Limits	Explanations
[P100]	“Nominal RMS Voltage Set” value. (U-V-W phase-phase voltage value)	VOLT (rms)	100 - 480 Default=100	Voltage Range Selection: 100Vac RMS to 480Vac RMS (factory default value: 100)
[P139]	“Volts Trimmer Effective range” value. (VLT Pot adjustment range)	%	0 - 30 Default= 30	Adjustment range: ±0% to ±15% of P100 parameter set value, (factory default value: 30)

Parameter [P100] sets the voltage regulation reference point with VLT trimmer set to its MID position.

EXAMPLE:

Set voltage regulation to 380Vac and VLT pot setting range to $\pm 15\%$ (320Vac rms to 440Vac rms):

- Set parameter [P100] to 380
- Set parameter [P139] to 30

The result is shown in table below:

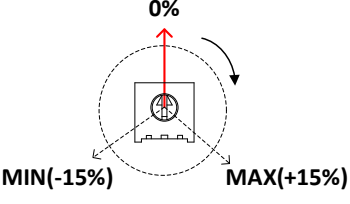
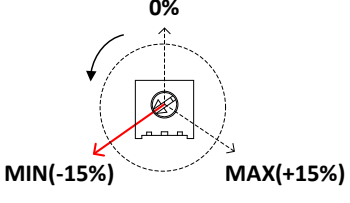
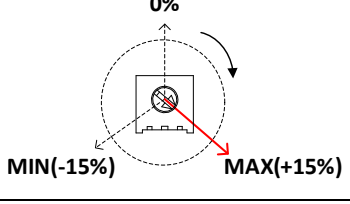
Parameter setting:	Alternator stator voltage (U-w):	VLT pot setting:	Explanation
<p>[P100] = 380 [P139] = 30</p> <p>(nominal stator voltage is set to 380Vac and pot range to $\pm 15\%$ of 380Vac)</p>	380Vac rms		VLT POT set to mid position (nominal set position)
	320Vac rms		VLT pot set to MIN. position (-15%, turned fully CCW)
	440Vac rms		VLT pot set to MAX. position (+15%, turned fully CW)

In the above example, AVR nominal regulation voltage level is set to 380 (Vac rms) and onboard VLT pot setting range is set to 30 ($\pm 15\%$). In this case, if the VLT pot position is set to MID position as shown in the table above (nominal voltage set value position), AVR will regulate the alternator voltage at 380Vac. Rotating the VLT pot to its minimum position (fully CCW) will reduce the alternator voltage down to 320Vac (-15% of nominal set value, set by parameter [P139]). Rotating the VLT pot to its maximum position (fully CW) will increase the alternator voltage to 440Vac (+15% of nominal set value). User can set the minimum and maximum voltage adjustment range by setting parameter [P139] according to requirement.

4.3: Setting the CT ratio on AVR unit:

If stator current is going to be monitored for line compensation or reactive droop compensation, CT must be wired across S1 and S2 terminals of the AVR unit. The CT ratio can either be set as X/1 or X/5 on the AVR unit. Therefore, based on the current transformer used on the alternator, user must set the transfer ratio of the CT on the AVR to ensure that, 1PU of stator current corresponds to the correct value through S1 – S2 terminals of the AVR unit.

This is done by setting parameter [P135] in the parameter list as shown in the table below:

Parameter number	Parameter Description	Units	Parameter Settings	Explanations:
[P135]	Current Transformer transfer ratio	PU of alternator current rating	205	X/5 ratio (1PU = 5A)
			1024	X/1 ratio (1PU = 1A)

4-4. External Pot connection (E1 & E2 terminals):

DAVR40 allows controlling of the alternator voltage via an EXTERNAL POT, connected away from the AVR unit. Connection is shown in figure below:

This pot can be mounted at a remote location on the generator to allow the user to “fine-tune” alternator voltage as required. Maximum cable length should not exceed 3m and must be shielded for safe operation if the cable length exceeds 1m. Up to 1m cable length, twisted cable pair can be used.

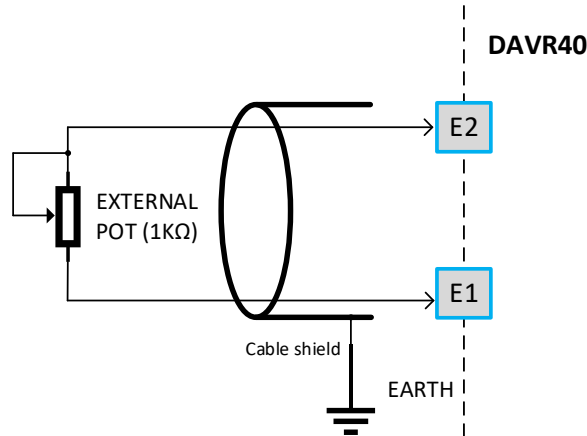

If the cable length exceeds 1m, it is recommended that a shielded cable is used, and the cable shield is connected to EARTH terminal near the AVR side only, opposite end of the shield should be left unconnected. DAVR40 detects the external POT connection and user is required to set the “External Pot Effective Range” parameter: [P142] to suit their application, as shown in table below:

Parameter number	Parameter Description	Units	Parameter Range:	Explanation
[P142]	External Pot Effective Range	%	0 - 30 Default=30	Adjustment range: ±0% to ±15% of set nominal voltage value (factory default value: 30)
[P123]	EXT. POT Enable/Disable	-	0 - 3 Default=0	Set P123 to “0” to ENABLE EXT. POT function.

External pot acts on the voltage set value by VLT pot and the device configuration parameters. In the example given below, the VLT pot is set to 380Vac rms (VLT trimmer pot set to MID position) and the “External Pot” effective control range is set to ±10% which corresponds to 380Vac ±38Vac effective external pot set range.

EXAMPLE:

Set EXTERNAL Pot adjustment range to ±10% for above shown example:

Parameter setting:	Alternator stator voltage (U-W):	VLT pot setting:	Explanation
[P100] = 380 [P123] = 0 [P139] = 30 [P142] = 20	380Vac rms		VLT POT set to 380Vac rms (trimmer at MID position)

USER MANUAL Automatic Voltage Regulators

<p>(nominal stator voltage is set to 380Vac and pot range to ±10% of 380Vac)</p>	340Vac rms		EXTERNAL Pot set to minimum (fully CCW)
	420Vac rms		EXTERNAL Pot set to maximum (fully CW)

4-5. AUXILIARY Analogue Signal connections:

DAVR40 is also equipped with an analogue AUX signal input terminal, where an external device can control the alternator voltage via 4-20mA, 0-10Vdc or ±5Vdc analogue signal, depending on the parameter selection in configuration software. By factory default, parameter “AUX Input Mode” [P123] is set to “0” and the function is disabled. If AUXILIARY signal input function is going to be used, “AUX Input Mode” must be enabled. The mode selection for AUX input is explained in the table below:

Parameter number	Parameter Description	Parameter Set limits	Explanation	
[P123]	“AUX Input Mode” (Terminals: A1, A2)	0	“AUX Input Mode” function DISABLED	“EXT POT” function is ENABLED
		1	-5Vdc to +5Vdc analogue voltage signal input	“EXT POT” function is DISABLED
		2	4mA to 20mA analogue current signal input	
		3	0Vdc to +10Vdc analogue voltage signal input	

	<p>If “P123 = 0” then “AUX Input Mode” function is automatically DISABLED and EXTERNAL POT input function is automatically ENABLED.</p> <p>Setting “P123 = 1, 2 or 3” values, EXTERNAL POT control function will automatically be DISABLED.</p>
--	---

AUXILIARY Analogue signal connection terminals are marked as “A1” and “A2” on the AVR plastic tray. Terminals are shown in figure below.

For best performance, the cable pair connected to A1 and A2 should be twisted pair or shielded type and should be installed away from power cables. If shielded cable is used, connect only one end to the GND terminal at the instrument side.

Type of signal interface is selected by setting parameter [P123] value as shown in table above. Remember that, if AUX input is ENABLED, EXT POT function is automatically DISABLED.

USER MANUAL Automatic Voltage Regulators

Parameter setting:	Signal type:	Connection:	Explanations:
[P123] = 1	±5Vdc input		<p>-5Vdc / +5Vdc analogue signal connection.</p> <p>A1 internally connected to AVR GND.</p> <p>A2 signal is referenced to A1 potential (GND) connection.</p>
[P123] = 2	4-20mA input		<p>4mA / 20mA signal connection.</p> <p>A1 internally connected to AVR GND.</p> <p>A2 signal is referenced to A1 potential (GND) connection with 100Ω SHUNT impedance.</p>
[P123] = 3	0-10Vdc input		<p>0-10Vdc signal connection.</p> <p>A1 internally connected to AVR GND.</p> <p>A2 signal is referenced to A1 potential (GND) connection.</p>

The effect of the AUX input signal on the AVR output voltage change can also be set. Therefore, 100% swing on the analogue input signal can only change the AVR output voltage with the limits set by parameter [P124] as shown in the table below:

Parameter number	Parameter Description	Units	Parameter set limits	Explanation:
[P124]	“AUX Input RANGE”	%	0 - ±15%	Sets the limit change of AVR voltage reference with reference to AUX input signal

The function description is given in the table below; the example shows the effect of AUX control signal on the alternator output voltage with “AUX Input RANGE” limit set to $\pm 10\%$ for a full 100% signal change across terminals A1 and A2:

Parameter setting:	Set Value:	Connection and control range:	Explanations:
[P123]	2		Parameter [P123] = 2 (AUX input set for 4-20mA signal type)
[P124]	20		[P124] = 20 (AUX input RANGE is set to $\pm 10\%$ affect for 100% change in the AUX input current signal value) (AVR output voltage is set to 400Vac nominal)

The control characteristics based on the AUX signal input is designed as a LINEAR relation such that the configured control range of the AUX signal input will change the AVR voltage reference in a linear manner. Same characteristics also apply to the trimmer pots on the AVR and their scan from minimum to maximum position reflects as a linear control on the voltage control function.

	Galvanic isolation is only provided between “Power Connection Terminals” group and “AUX and Communication Terminals” group and rated at 500Vac. If AUX terminals are connected to an external control device, remember that there is no isolation between “USB port” and the “AUXILIARY analogue input terminals”.
--	--

5- PID Parameters Settings (Stability control):

DAVR40 is designed in digital concept, using state-of-the-art microcontroller technology and the overall dynamic performance of the AVR can be precisely set to perform in any application. To achieve this, user needs to set the PID parameter settings such that, AVR dynamic behaviour matches the alternator response characteristics as best as possible.

The following information walks the technical user of this manual through a set of practices to achieve the stability settings of the AVR unit for best performance operating on any alternator. The dynamic behaviour of the AVR together with the diesel engine can also be optimised and this is also shown in the related chapters of this manual.

5.1: Understanding DAVR40 Dynamic Behaviour:

DAVR40 design is based on “Digital Control” technology where all the sensing signals are converted into digital values and processed at very high-speed during operation. Since the AVR is designed to be used on a wide range of alternator frames, the response characteristics of the AVR must be set to control the dynamic behaviour of the alternator type and this is mainly achieved by setting the PID coefficients as close as possible to the ideal values, required by the alternator.

In other words, by setting the correct PID coefficient values, you must optimise the following characteristics of the alternator:

- Steady-state regulation of the alternator stator voltage,
- Undershoot (maximum allowed voltage dip) characteristics of the alternator with sudden load application to the alternator,
- Overshoot (maximum allowed voltage rise) characteristics of the alternator with sudden load removal from the alternator,
- Recovery time in “seconds”,

General dynamic behaviour of a Generator set is shown in the graphics below:

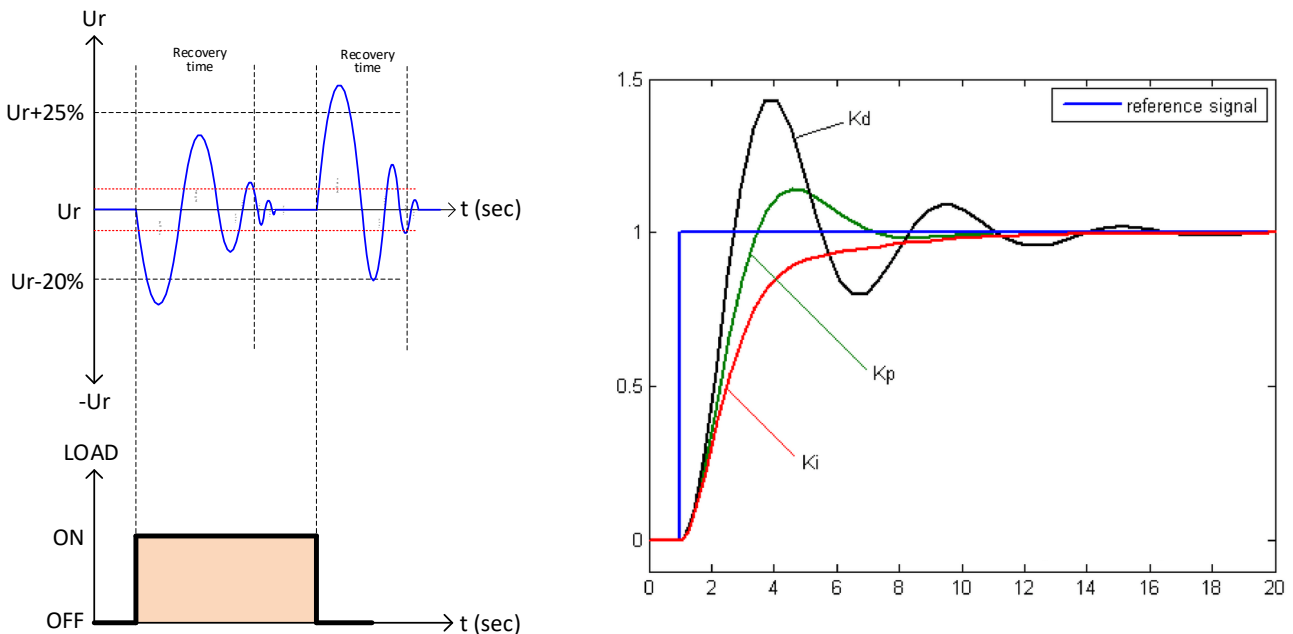

The limits of the recovery time and the transient response levels are determined by ISO8528-5:2018 and user should set AVR PID and LAM parameters to ensure that overall generator can perform according to the required “G” class operational limits.

5.2: Using “STB” trimmer on the AVR unit:

There is an integrated stability trimmer pot (STB pot) on the AVR unit, and this trimmer has a limited set range during operation to allow the user to trim the K_P value of the PID parameters, set by the configuration software. This only allows a limited trimming range to allow the user to fine-tune the steady-state regulation behaviour of the AVR. Main settings of PID parameters must be adjusted, using the configuration tool software and the AVR parameter set.

The STB trimmer effective setting range can also be set using parameter [P140]. By setting the value of this parameter, the effective adjustment range of the STABILITY trimmer pot and this is shown in the table below:

Parameter number	Parameter Description	Units	Parameter set limits	Explanation:
[P140]	“STB” Trimmer pot adjustment range	%	0 - 30	Changes the value of K_P as % of the value set by parameter P110

The PID parameter descriptions are given in the table below:

Parameter number	Parameter Description	Set limits	Explanation
[P110]	Coefficient of Proportional K_P value	0 - 2048	Proportional coefficient of the controller. Increasing it will cause faster AVR reaction but worse steady state stability.
[P111]	Coefficient of Integral K_I value	0 - 2048	Integral coefficient of the controller. Increasing it will cause better steady state stability but worse reaction time.
[P112]	Coefficient of Differential K_D value	0 - 2048	Derivative coefficient of the controller. Increasing it will cause faster AVR reaction but worse steady state stability.

5.3: Definition of K_P (Differential Coefficient) parameter:

K_P parameter value sets the “Proportional Gain” of the PID function of the AVR unit. This value must be set according to the steady-state voltage regulation ripple value and must satisfy the performance requirements set by the AVR specifications as closely as possible.

K_P parameter reacts to the present error by applying a correction value proportional to the deviation from the set reference point. Increasing the value of this coefficient can enhance the response time but can lead to overshoot and oscillations and too low values will reduce the system response to sudden actions. Therefore, when setting this value, take care to make sure that voltage regulation ripple is within the specified limits and response time is not too slow.

This coefficient value must be set in relation to K_I and K_D coefficient values, based on the required response of the alternator system.

5.4: Definition of K_I (Integral Coefficient) parameter:

K_I parameter value sets the “Integral Gain” of the PID system, which accumulates the past errors and applies corrections to eliminate the steady-state errors. Too high setting of this coefficient may cause instability in the system response to load changes on the alternator. Too low settings will reduce the capability of the system to correct errors completely but improves persistent oscillations in the system

This value also must be set according to the other PID parameters to get the best performance with sudden load changes on the alternator.

5.5: Definition of K_D (Differential Coefficient) parameter:

K_D Coefficient parameter is the derivative gain value and corrects the future trends of the load behaviour based on the rate of change of error. Increasing this value will eliminate the overshoot and dampen the system but excessive values will amplify noise components in the response characteristics.

Low value settings will reduce the system response time to sudden load changes on the alternator. The value of differential coefficient must be set together with the integral and proportional coefficient values to get the best performance characteristics.

As a practical approach, PID settings can be done as follows:

1. Set K_I and K_D to a low level and slowly increase K_P coefficient value until the voltage regulation starts to oscillate,
2. Then start increasing K_I to eliminate the voltage ripple to get smooth voltage regulation on the alternator output,
3. Then introduce K_D to get best performance with step load change,
4. Repeat the value settings to make sure that best dynamic performance is achieved under all operating conditions,
5. Use factory settings for PID values for DAVR40 to start fine tuning the values to get best dynamic performance with the alternator,

5.6: Steady State Voltage Regulation:

Although PID coefficients set the performance for the “Dynamic Performance” of the AVR and the Alternator, care must also be taken when setting the “Steady-State” voltage regulation and the “Voltage Ripple” with no-load conditions. User must set the PID gain values in order to get the best “steady state” voltage regulation as stated in the AVR technical specifications document. “Steady-State” voltage regulation defined in the table below:

Parameter Description	Units	Function Description	Explanation:
Steady-State Voltage Regulation	%		$V(\text{ref}) \pm 0.5\%$ (specified ripple factor)

As an example, if stator voltage reference value is set to 400Vac, then the AVR can achieve a steady-state voltage regulation with a ripple factor, less than $\pm 2V_{pk}$.

5.7 Reference Change “Ramp Limit” function:

When changing the voltage reference either from software or using VLT pot on the AVR or using the EXTERNAL Pot, it is possible to smooth the “Voltage change Response” with respect to the unit change in reference regulation voltage value so that, the alternator stator voltage has smooth and slightly delayed control to avoid any unwanted fluctuations due to setting inconsistency. It is possible to set this with parameter number [P107] and function description is explained in the table below:

Parameter number	Parameter Description	Units	Parameter set limits	Explanation:
[P107]	Reference Change RAMP limit function	V/s	0 - 100	Sets some time delay while changing the voltage reference value of the AVR

5.8: Dynamic behaviour of AVR based on PID settings:

By carefully setting the PID parameter values, it is possible to adopt the AVR to perform under any operating conditions with a wide range of alternator frame sizes. The effects of P, I and D coefficient settings of the AVR unit is described in basic terms in the following table:

K_P, K_I and K_D coefficients	ALTERNATOR RESPONSE
<p><u>AVR PID settings “Under-damped”:</u></p> <p>K_P and K_D coefficients set too high, K_I coefficient set too low!</p> <p>(Step load response is under-damped, and ringing is high, transient peaks are high)</p>	<p>The graph illustrates the alternator response to a step load change. The top part of the graph plots voltage (U_r) against time (t). A step load is applied, causing the voltage to drop from U_r to $U_r - 20\%$. The voltage then oscillates around the U_r level before settling back to U_r. The time taken to settle back to U_r is labeled as 'Recovery time'. The bottom part of the graph plots LOAD against time (t), showing a step function that goes from OFF to ON and then back to OFF.</p>

AVR PID settings “Over-damped”:

K_I coefficient is set too high and K_D and K_P coefficients are set too low!

(Step load response is Over-damped, and ringing is moderate, transient peaks are within limits, but recovery time is too long)

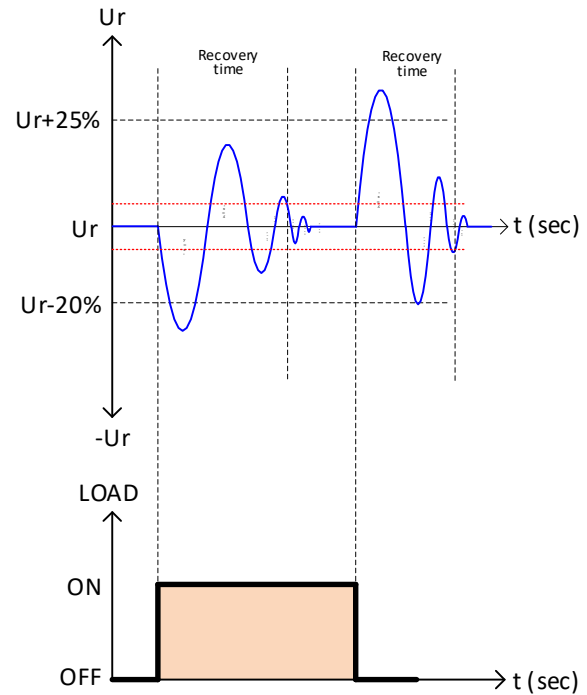

AVR PID Parameters set correctly:

K_P , K_I and K_D coefficients set correctly,

(Transients are within operational limits, recovery time is according to G1, G2 or G3 operating limits)

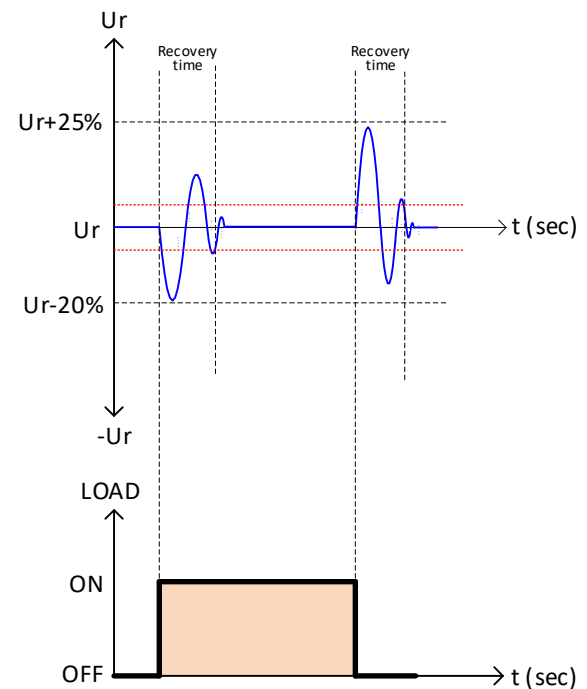

5.9: Management of set PID parameters:

DAVR40 requires PID parameters settings for any specific alternator model based on alternator design parameters and their dynamic transient response characteristics. Once best PID settings are determined, the parameter set can be saved and automatically recalled for future applications.

PC Configuration software allows the user to save the parameter sets for any specific alternator frame size and can be recalled for automatic download during production phase. This means that; PID parameter tuning is to be set only for once per different alternator type and recalled for future use.

6- “Load Acceptance” Parameter Settings:

DAVR40 has excellent algorithms to allow high performance during operation in a genset configuration. Based on the engine response time and characteristics with high “Block Load” application, DAVR40 behaviour can be set to ease the burden on the diesel engine and at the same time, control the alternator excitation drive to ensure excellent performance characteristics for demanding applications.

By setting the parameters carefully, it is possible to down-size the prime mover to handle high-capacity sudden load applications and yet stay within ISO8528 standard operating limits.

6.1: Setting UFRO parameters:

To protect alternator excitation system, based on the speed of the prime mover, DAVR40 unit can be configured to reduce the excitation of the alternator, hence reduce the stator voltage to prevent over-excitation of the alternator. Two parameters are available to set the frequency roll-off point and the slope of the voltage reduction with respect to the frequency. These two parameters are [P117] and [P118] respectively. Parameter settings are explained in the table below:

Parameter number	Parameter Description	Set limits	Explanation:
[P117]	UFRO Knee Point (Hz)	40 - 65	
[P118]	DIP Rate (V/Hz)	0 - 80	

The slope parameter [P118] sets the rate of voltage reduction per hertz drop in frequency. This parameter setting also effects the behaviour of the alternator when recovering from a DIP condition and this is also part of “Load Acceptance” function (LAM) configuration. Therefore, setting the negative voltage slope with respect to frequency will also affect how the system will recover from a sudden load state.

The V/Hz parameter indirectly sets the excitation current of the alternator to maintain safe limits to how much current is injected to the field winding. Users must select the parameter value carefully to ensure that overall system performance is according to their expected behaviour.

6.2: Setting “Load Acceptance” parameters (LAM):

LAM function is designed to increase the recovery capacity of the generator when a sudden block load is applied to the generator output. LAM function acts upon the frequency variance of the generator with sudden high load application and accurately adjusts the AVR voltage set point to allow the generator to recover from its high dynamic stress status.

LAM function adjust trimmer pot on the AVR unit allows the user to set the behaviour of the generator, according to the required sudden block load recovery capability of the overall system. LAM function is a complex function, and it covers the whole period, from sudden load application to complete recovery of the generator system. LAM function is simply illustrated below:

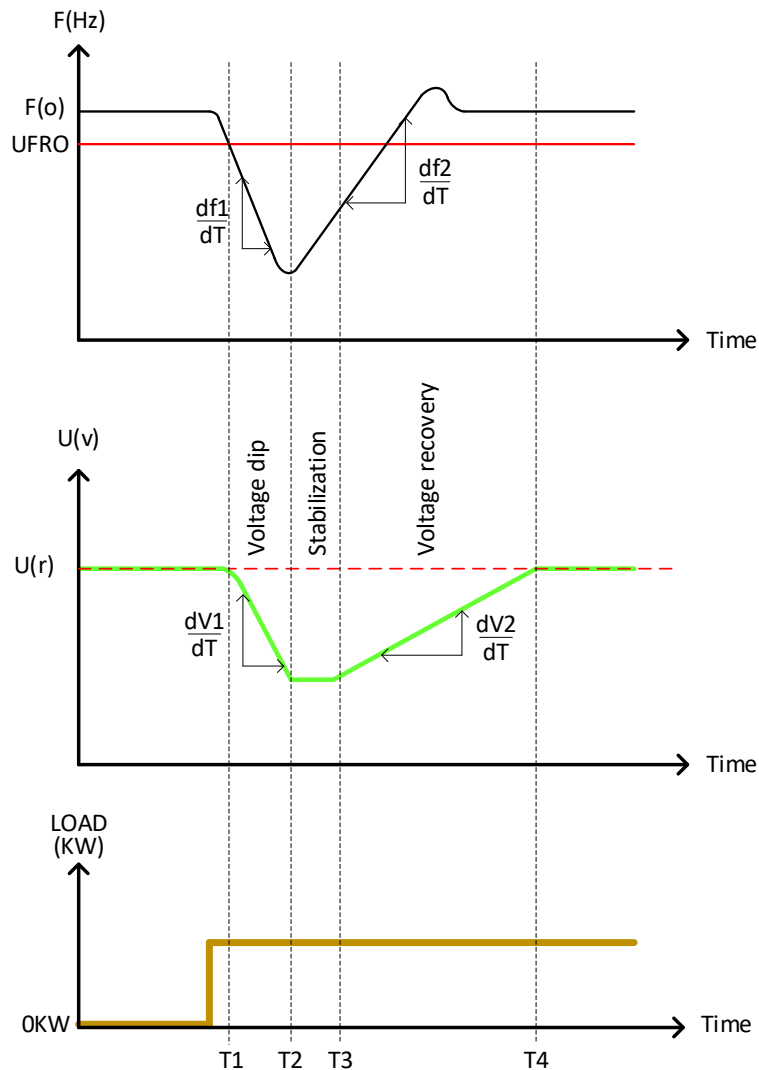

Setting [P118] = 0 will cancel the function, means that there will be no voltage reduction when block load is applied to the generator. When load is applied to the generator output, AVR will try to keep the alternator voltage according to the set regulation level. In applications where there will be no sudden high load applications to the generator, this option may be preferred to ensure stiff voltage regulation against load variations based on the load capacity and diesel limits.

6.2.1: Setting DWELL parameters:

To set the recovery characteristics following a voltage DIP condition, it is required to set the time the voltage rises back to its nominal set voltage regulation reference value. In other words, the slope of recovery characteristics must also be set before the generator can return to its normal operating conditions.

To set this characteristic, parameter [P119] (DWELL time) is used. This parameter is also further enhanced with parameter [P120] (LAM Mode Selection), which selects the type of recovery characteristics from a DIP state. DAVR40 allows two different recovery characteristics, which can be set by parameter [P120], and the detailed operation is shown in table below:

Parameter number	Parameter Description	Set limits	Explanation:
[P119]	DWELL Time setting (+dV/dT) V/sec	0 - 480 Default= 0	
[P120]	LAM Mode Selection (No-DELAY mode)	[P120] = 0 (Normal mode)	
Parameter number	Parameter Description	Set limits	Explanation:
[P119]	DWELL Time setting (+dV/dT) V/sec	0 - 480	
[P120]	LAM Mode Selection (DELAY Mode)	[P120] = 1 (Enhanced mode)	

6.2.2: Setting Minimum Voltage Reference Percentage:

During LAM parameter settings, if user is going to comply to ISO8528 standards for operating limits, the minimum voltage DIP level is required to be set according to the “G” performance class and in this case the minimum voltage DIP level needs to be also controlled and set by the parameter configuration menu. To set the minimum voltage DIP level, parameter [P109] needs to be configured. The parameter details are explained in the table below:

Parameter number	Parameter Description	Set limits	Explanation:
[P109]	Voltage DIP Level (% of U(r))	0 - 100 Default= 75	

In the example above, Voltage Regulation reference is set to 400Vac (alternator is generating 400Vac) and if [P109] = 50, it will allow the voltage DIP to limit at 50% of 400Vac, which is 200Vac. In this case, DAVR40 will try to maintain the DIP voltage level at 200Vac even if the frequency drop exceeds the “DIP Rate” determined voltage level.

7- “Droop” Parameter Settings:

DAVR40 unit has integrated CT for measuring the alternator load current and based on phase angle and magnitude of the stator current vector, it can perform reactive load compensation and also, resistive line drop compensation. The operation mode can be set with parameter number [P137] and the effective adjustment range of the on-board DROOP trimmer can be set with parameter number [P141].

Parameter Number:	Setting Range:	LINE VOLTAGE DROP COMPENSATION	DRP POT Setting
[P137] = 0 [P141] = 0 (DROOP function Disabled)		<p>U (volts)</p> <p>(No compensation based on the stator load current)</p>	<p>“DRP” Pot disabled.</p>
[P137] = 1 [P141] = 3 (LINE DROP Compensation set for 3%)	[P137] (0 – 3) [P141] (0 – 10)	<p>U (volts)</p> <p>(LINE DROP compensation mode enabled)</p>	<p>“DRP” Pot set for LINE DROP compensation</p>
[P137] = 2 [P141] = 10 (LOAD BALANCE Compensation set for 10%)		<p>U (volts)</p> <p>(LOAD BALANCE compensation mode enabled)</p>	<p>“DRP” Pot set for LOAD BALANCE compensation</p>

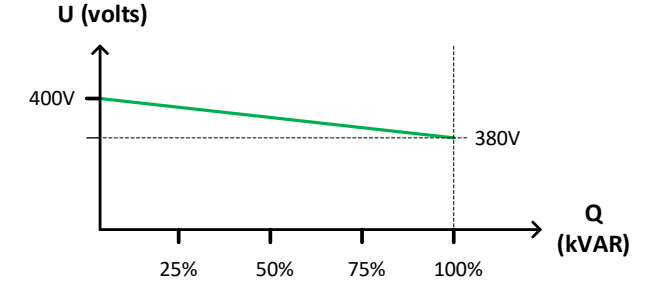
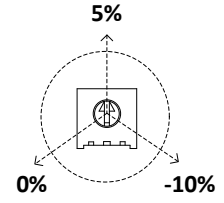
<p>[P137] = 3 [P141] = 10</p> <p>(REACTIVE DROOP Compensation set for 10%)</p>	<p>[P137] (0 – 3) [P141] (0 – 10)</p>	 <p>(QUARATURE DROOP compensation mode enabled)</p>	 <p>“DRP” Pot set for REACTIVE DROOP Compensation</p>
--	---	---	--

If “LOAD BALANCE” mode is selected ([P137] = 2), DAVR40 calculates the stator load magnitude and compensates the set “Voltage Reference” of the AVR to release the load burden on the Generator. This is particularly practical if the Generator is feeding high-motor-load, and the prime mover can relax to feed the load without tripping the secondary protection devices.

7.1: “Droop” Phase Compensation:

In applications where many generators are connected to the same busbar, the reactive component from each generator is equally shared by the number of generators on the same busbar. When different power rated and/or different brand generators are connected to the same busbar, it may sometimes require correcting the phase angle of the reactive component on the CT measured current vector. On DAVR40 this can be achieved by setting the correct phase angle so that each AVR can precisely compensate for the phase- angle error and hence share the reactive load equally and more precisely. The parameter definition is shown in the table below:

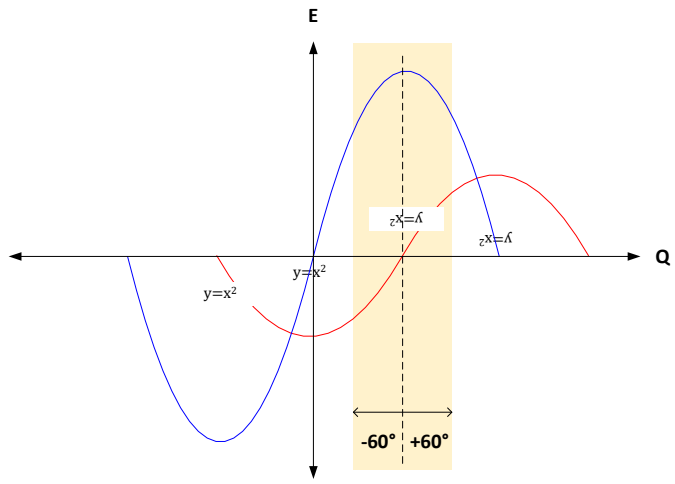
Parameter Number	Parameter Description	Setting limits	Explanation:
<p>[P138]</p>	<p>DROOP Phase compensation</p>	<p>±60°</p>	

8- AVR “START SEQUENCE” Control:

DAVR40 Voltage Regulator unit is designed with comprehensive “START CONTROL” functions and can be tailored to fit all demanding applications.

The DAVR's starting procedure in AVR mode can be configured using the “Starting Frequency” and “Starting Time Delay” parameters. The “Starting Frequency” defines the minimum generator frequency at which the DAVR begins regulating voltage. Once this frequency is reached, the “Starting Time Delay” parameter determines the additional waiting time before the DAVR activates field excitation.

The “Starting Frequency” is measured from the sense input terminals and ensures that the generator reaches a stable operating speed before voltage regulation begins. The “Starting Time Delay” allows further control by introducing a controlled delay after the frequency threshold is met. This delay can be useful for synchronizing multiple gensets in parallel operation or for delaying the application of load to the generator. Proper configuration of these parameters helps prevent premature excitation and ensures a smooth startup sequence.

START sequence has the following control zones, which can be configured via PC-Tools SW menu. The AVR unit will drive the excitation (voltage regulation) based on the conditions set by the user. The following start sequence features can be set:

1. Frequency (rpm) dependent start delay,
2. Time dependent start delay,
3. Ramp fitted start sequence,
4. “Start” control from menu parameter set,
5. “Start control” via an external signal,

The above start-sequence parameters should be set by the user to define the start characteristics of the alternator, based on the operation of the prime mover. The alternator residual voltage seen across the P1 and P2 power input terminals must be at least 6Vac to automatically start the voltage build-up on the alternator stator windings. If the residual voltage is below 6Vac, the AVR may not have sufficient energy to start excitation. In this case, the excitation winding needs to be briefly flashed with a 9V battery, connected with the correct polarity to the F- and F+ terminals.

A graphical representation of the start sequence functions is shown in figure below:

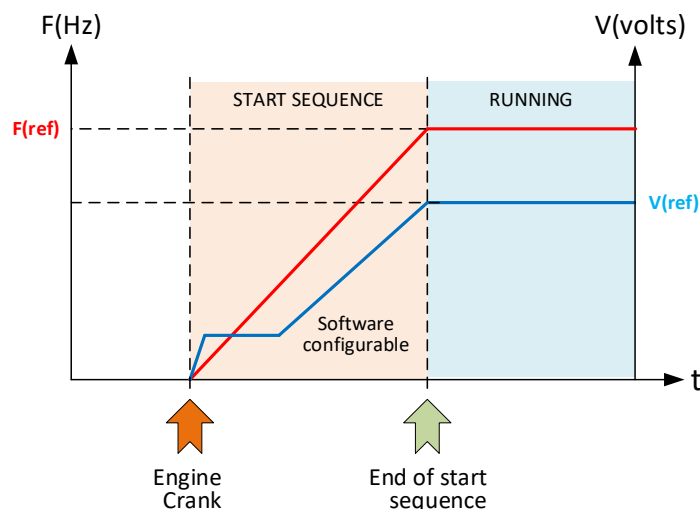

As graphically shown above, the START SEQUENCE of the AVR must be configured to suit the required application. The sequence starts with the engine cranking and ends with the user determined condition, where normal AVR mode operation (normal voltage regulation) starts. This can vary from a few milliseconds to almost 2 hours (7200 seconds) which can fit for almost any demand in the field.

In addition to the configurable “Start Sequence” features, the AVR operation can be put in “HALT” condition by activating one of the configurable digital inputs. This feature, together with the “Start Sequence” features make

DAVR40 AVR unit suitable for special applications, where the prime mover cannot start immediately like the classic diesel engines.

“Start Sequence” can also be activated via “External Start” control input, which is described further in this user manual. If “Start Sequence” parameters are set according to user requirement, AVR will start operation with set start pattern, after receiving the “External Start” signal from one of its programmed digital inputs.

The “START SEQUENCE” features are described in more detail below:

8.1: “Starting Frequency” Delay function:

DAVR40 operation can be delayed until the prime mover reaches a predetermined speed (alternator frequency sensed across the sensing terminals) level and at this instant, AVR will check other linked “Start Sequence” parameters and control the alternator excitation accordingly.

The DAVR's starting procedure in AVR mode can be configured using the “Starting Frequency” and “Starting Delay” parameters. The Starting Frequency defines the minimum generator frequency at which the DAVR begins regulating voltage. Once this frequency is reached, the Starting Delay parameter determines the additional waiting time before the DAVR activates field excitation.

“START FREQUENCY DELAY” function is set with the parameter number [P105], and the function is described in more detail in the following table:

Parameter Number	Parameter Description	Setting limits	Graphical presentation:
P105	START FREQUENCY Delay control function	25 - 75 (Hertz)	

Until the start frequency is reached (25Hz minimum), AVR will regulate the alternator voltage at around 60Vac to maintain its own power to the AVR hardware. If the residual voltage level of the alternator is higher than this level, the AVR will operate at this residual voltage level, until the start sequence begins. A minimum of 6Vac across P1, P2 and P3 is required to start the AVR control. If this voltage level is not reached during start of the operation, AVR may not be able to start controlling its excitation drive function. If PMG is used to power the AVR (2-phase), starting from residue voltage will not be any concern for the AVR unit.

AVR STARTING control parameters are used in combination with each other and must be set according to the application requirements. The following START CONTROL parameters should be set together to control the AVR as per application requirements.

8.2: “Start Time Delay” Function:

Once the “START FREQUENCY” limit is reached, AVR will check the START TIME Delay period and control the AVR excitation function according to its set parameter values. “START TIME Delay” function and its related parameter settings explained in more detail in the table below:

Parameter Number	Parameter Description	Set limits	Graphical presentation:
[P104]	AVR START TIME Delay function	0–7200 (seconds)	<p>The graph shows Frequency F(Hz) on the left y-axis and Voltage V(volts) on the right y-axis, with time t on the x-axis. A red line represents the frequency, starting at 'Engine Crank' and rising to 'F (nom.)'. A blue line represents the voltage, starting at 'Engine Crank', remaining at a low level until time T0, then rising to 'V(set)'. The area between T0 and T1 is shaded blue and labeled 'Time dependent Controlled DELAY zone'. The area before T0 is shaded green and labeled 'Residual Voltage control zone'. The area after T1 is shaded yellow and labeled 'Controlled AVR regulation zone'. A horizontal dashed line at 25Hz is also shown.</p>

“START TIME Delay” value is set by parameter “P104” and can be adjusted between 0 sec. to 7200 sec. time duration. The timing will start at (T0) after the START FREQUENCY value is reached by the prime mover. Until the end of start delay time, DAVR40 will regulate the alternator phase voltage at around 60Vac. This is required to maintain power to its own hardware circuit inside the AVR. If the residual voltage is higher than this value at the prime mover’s “IDLE” or “RUNNING” speed (prime mover speed can be set to any level during this period, provided that it is running at its nominal speed before the “Start Delay” time T1 is ended), this will not affect the normal operation of the AVR unit.

During “Start Delay” period, AVR will not start “Excitation” and wait at REST condition, until the end of the “Start Delay” period. At the end of this controlled delay time, if the prime mover has exceeded the minimum operating frequency level (25Hz) and if the operating frequency is equal or more than the “Start Frequency” value, controlled excitation will start and set voltage regulation will be reached.

8.3: “Soft Start Ramp” Function:

The Startup Voltage Ramp is a controlled voltage increase phase that begins after the Starting Frequency and Starting Delay conditions are met. Once the delay time has elapsed, the DAVR gradually increases the output voltage toward the configured set voltage using a ramp rate defined in volts per second (V/S).

This controlled ramping prevents sudden voltage surges, reducing stress on the alternator and/or generator connected loads, and power system components. It ensures a smooth and stable transition to the operating voltage, minimizing inrush currents and mechanical strain on the generator. Proper configuration of the Startup Voltage Ramp is essential for optimizing startup behaviour, especially when operating in parallel with other generators or supplying sensitive loads.

“SOFTSTART RAMP” delay function checks that both set starting frequency conditions are satisfied and also, the “START DELAY” time has already elapsed, following these two conditions the AVR will act according to the set value of “SOFT START RAMP” parameter. The related parameter number is “P106” and can be set between 0 to 7200 seconds. The parameter and its function are explained in more detail in the table below:

Parameter Number	Parameter Description	Setting limits	Graphical presentation:
[P106]	SOFT-START Ramp function	1 - 7200 (Seconds)	

8.4: “Auto-Start” Enable/Disable:

DAVR40 has a control parameter to allow the excitation to either start AUTOMATICALLY or wait for an external “START” Signal from an external device or from the START parameter setting internally. To control the Auto-Start function, parameter [P102] can be used. Detailed parameter description is given in the table below:

Parameter Number	Parameter Description	Setting limits	Explanations:
[P102]	AVR AUTO-START control parameter	P = 0 (Disabled)	AVR in “HALT” state
		P = 1 (Enabled)	AVR in “RUN” mode (if the alternator is running and there are no alarm conditions)

8.5: “External Start/Stop” Control function:

(“Remote Start” & “Remote Stop” Control Function for DAVR40)

The DAVR40 can be controlled externally with an external control signal from peripheral control devices. In this mode, AVR excitation output can be forced into “HALT” status, until a “START” or “STOP” signal is sent from an external control device to the AVR unit.

As outlined in previous sections, DAVR40 is fitted with a “Temperature Measurement” input (ADT Input), which can also be set as “Digital Input” via parameter settings. This configurable input (T1-T2) can be set as a “digital input” and configured by pre-set functions. “EXTERNAL START” or “EXTERNAL STOP” signal is applied via external potential-

free relay contact across T1-T2 input terminals. Applying a “closed contact” to the digital input (shorting the terminals with an external dry contact) activates that function (TRUE). The operation is shown in the table below:

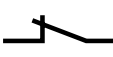
Parameter Setting	Parameter Description	External control input	Explanations:
[P102] = 0	“AUTO-START” disabled	 (T1-T2)	Remote Start / Stop “FALSE”
		 (T1-T2)	Remote Start / Stop “TRUE”

8.6: Manual “Start Control” with parameter setting:

It is possible to “START” or “STOP” the AVR functioning manually, by setting parameter [P101] from the PC-Tools menu. This parameter also indicates if there has been an automatic HALT due to an alarm state of the AVR. Parameter function is described in the table below:

Parameter Number	Parameter Description	Setting limits	Explanations:
[P101]	AVR START status control parameter	[P101] = 0 (STOP)	AVR in “HALT” state. If set manually, it overrides all other START commands on the AVR. If there is an ALARM condition during normal operation, this flag is set to “0” automatically and needs to be set manually, or AVR power must be RESET.
		[P101] = 1 (START enable)	AVR in “RUN” mode (if the alternator is running and there are no alarm conditions) This parameter can be set manually from the menu to START or STOP the AVR functions manually during testing.

This parameter has also a “FLAG” action and automatically sets to “0” if there is an “active alarm” condition. Setting this parameter to “1” manually will enable normal operating of the AVR but if there is an active alarm condition, [P101] automatically sets back to “0” internally.

Refer to the related section of this manual on ADT input configuration settings to understand how the ADT input can be set to control the AVR START/STOP by an external control signal.

9-Configuration of AUXILIARY Inputs:

DAVR40 is designed with an ADT input (Analogue/Digital/Temperature) and the characteristics of this input can be configured according to user requirements. AUXILIARY inputs are shown below

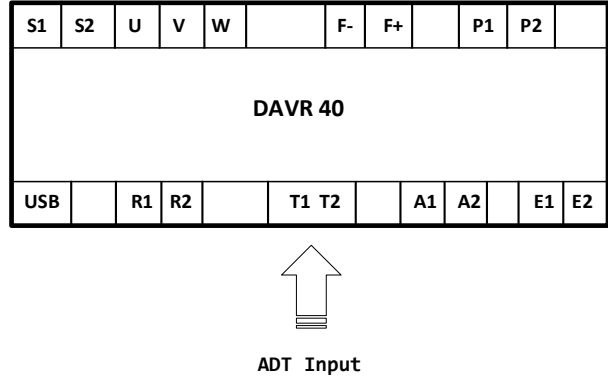

There are various options which the user can choose from, and these options are shown in the table below:

Parameter Number	Parameter Description	Setting options for parameter P270 and P277	Explanations:
[P270]	ADT input	0 = Disabled 1 = Analogue type input (MODBUS only) 2 = Digital type input (MODBUS only) 3 = Winding temperature input 4 = Auxiliary temperature input 5 = External START 6 = External STOP	ADT input (terminals T1 and T2)
[P271]	Monitoring only		
[P272]			

The AUXILIARY input can be set to have certain pre-determined characteristics as described in the above table. If temperature is going to be measured, only RTD type temperature sensors can be used and detailed configuration and calibration can be executed in the PC-Tools software menu.

If the “ADT” input is set to “0”, this action will disable the AUX channel, and the microcontroller will not read any values from this channel. It will be good practice to disable (set [P270] to “0”) any AUX channel, which is not going to be used in the application.

If the AUX channel is set to “1”, this will set the channel to read an “Analogue Signal” connected to the selected AUX terminals of the AVR. This mode is only available for MODBUS applications via USB port, and more data is available in PC-Tools SW package on how to configure the set up for analogue data transmission.

If a “Digital input” signal is to be connected to the AUX terminals, then channel parameter must be set to “2” and in this case, a dry-contact digital input (potential-free contact input) can be detected by the AVR unit. This input can be linked to certain functions in the AVR, using PC-Tools SW menu. AUX input can be used to measure the winding temperature on the alternator. If required, an external temperature point can also be read by the AVR, when connected to a Pt100 temperature sensor. Certain functions can be linked to this input, and limits can be set for alarm or AVR shut-off function.

Setting AUX parameter to “5” or “6” can control the AVR excitation from a remote device. A dry-contact input is required to activate the function, based on the selected configuration. Remember that the function will only be “TRUE” if the selected AUX terminal has a short-circuit across its terminals, otherwise it is a “FALSE” state input.

The data registers at [P271] and [P272] for ADT input channel are “read-only” registers. When connected to the PC-Tools SW package, user can monitor these registers and track the activity on the AUX channel inputs.

10- “Field Winding” connection (Alternator EXCITATION):

DAVR40 is designed to start automatically from residual stator voltage at start-up phase. Residual magnetism on the rotor excites a small residual voltage on the alternator stator windings and AVR unit can start the excitation process from this low residual voltage.

Minimum required residual voltage is 6VAC (rms) across the point of power connections (P1 and P2 terminals) of the AVR unit. Notice that if STAR- SERIES connection is used and power to the AVR is fed from the mid-winding terminals, minimum 6VAC is required between these terminals.

Alternator voltage will start to build-up as the engine rpm starts to increase, and regulation process will start approximately around 20Hz (600rpm for a 1500rpm generator system). FIELD winding connection is polarity sensitive and when connecting the field terminals, user must ensure correct polarity connection is made.

Connection schematic is shown below:

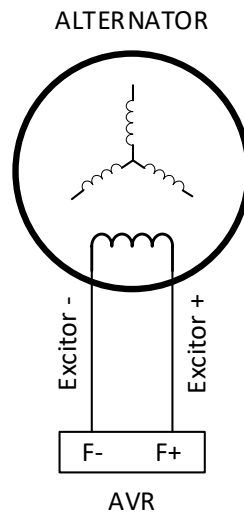

If the AVR does not start automatically when the prime mover starts, it is advised to control the residual voltage across the power input terminals of the AVR unit. If it is low, then the field winding needs to be flashed, using a 9Vdc battery. Make sure that the battery connection polarity and the field polarity is correctly placed before flashing the field winding.

If SHUNT power connection configuration is selected, make sure that the voltage limit is not exceeded across the power terminals of the AVR, P1 and P2.

DAVR40 has SCR controlled drive for FIELD winding and can deliver maximum 10Adc for limited time. Under normal operating limits, the unit can deliver 5A continuous into the FIELD winding at maximum operating temperature conditions. It is required that, the AVR is mounted such that the air around the AVR heatsink is freely ventilated.

For proper mounting conditions of the AVR, please refer to the “Mechanical Installation” chapter of this manual.

10.1 FIELD drive current:

DAVR40 has a continuous FIELD drive capacity of 5.0A_{dc}, and user must select the correct model according to their application requirements. Field drive capacities are shown in table below:

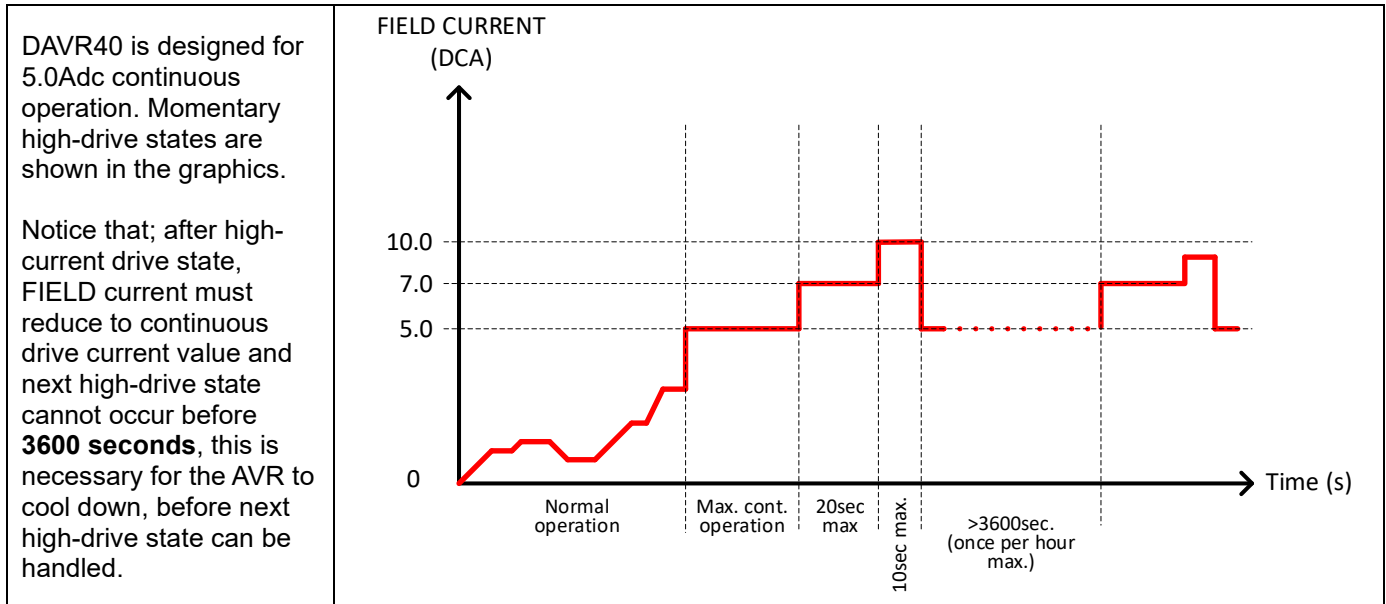

For reliable operation of the AVR unit, the specified limits of the AVR should not be exceeded. Excitation drive limit data is given as a guidance only and operating conditions may change these limits. It is always recommended that, AVR mount location is well ventilated and there is enough room for free air flow during operation. Also, it is a good practice not to mount the AVR very close to heat radiating elements.



Alternator “Excitation” winding characteristics MUST be considered to determine the maximum limits of the system with the AVR. AVR limits do not guarantee a safe operation condition for the “Excitation” winding of the alternator. When configuring the AVR limits, user MUST also consider the limits of the alternator windings at the same time.

FIELD Overexcitation function is designed to calculate the thermal build-up energy in the FIELD winding and the function is based on the IDMT operation curve characteristics of fuse operation. In this function, the AVR measures the magnitude of the Excitation current and integrates this value against the time parameter and based on the mathematical model built into the AVR unit, the approximate Excitation temperature is calculated and OVEREXCITATION protection function acts upon the outcome of this calculation.

If correctly set, this function can protect the alternator winding limit conditions based on the alternator loading and the excitation current pattern. This function can be configured via PC-Tools software menu.

10.1.1: “Safe-Operating-Area” (SOA) curve of Excitation Output:

DAVR40 can deliver full rated excitation current over its entire operating temperature range. There are “built-in” protection functions to prevent the AVR and the alternator field winding being damaged during overexcitation conditions and these are explained in detail in this manual.

Apart from the “built-in” protection functions (can be configured by the user), there is also thermal limitation by design of the DAVR40, which the user must consider during operation or installation of DAVR40 in their application. If there is limited air circulation in the location where the AVR is fitted, user **MUST** ensure that, the AVR always stays within the “Safe-Operating-Area” curve, given in detail below:

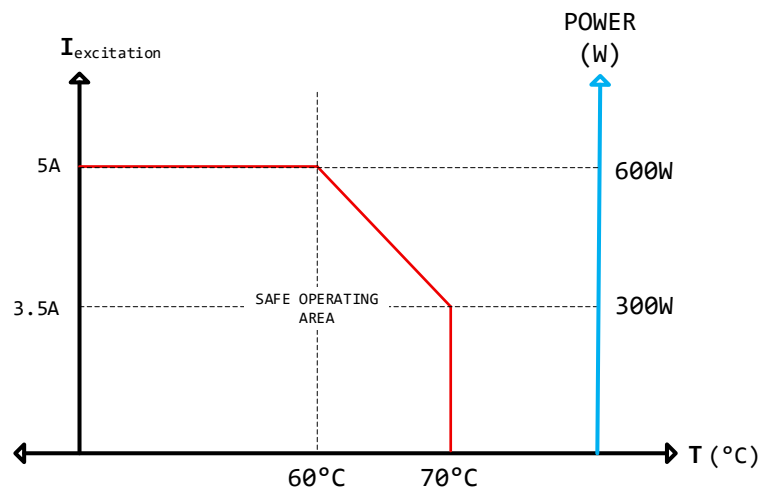

Figure 2: Safe Operating Area (SOA) for DAVR40

In the above SOA diagram, temperature axis is the temperature of the AVR’s operating environment. If the AVR is mounted in an enclosed environment, where there is no free air movement for convection, the self-heating effect of the AVR can also increase the environment temperature within the enclosure. The self-heating effect of the AVR will increase the temperature of its environment above the outside temperature.

Therefore, when installing the AVR, ensure that the installed area has free air movement and under all conditions, the operating conditions of the AVR (considering the continuous excitation current and the AVR’s environment temperature) stays within the given limits in the above SOA diagram.

Since SOA limits are not strictly controlled by the AVR, user must ensure the proper operating conditions for the AVR under all operating conditions of the generator.

10.1.2: POWER limitation of Excitation Output:

Although DAVR40 can deliver 5A continuous Excitation Current into the FIELD winding, based on the AVR power input voltage and the FIELD winding impedance, total power dissipation of the drive stage can increase above the limits of the cooling capacity of the heatsink. Therefore, under specified conditions, total Excitation Power delivered into the FIELD winding cannot exceed **600W**, which should be considered during installation. The limit should be calculated according to the formula indicated below:

$$P_{\text{EXCITATION}}(\text{W}) = (I_{\text{FIELD}})^2 \times R_{\text{FIELD}} < 600\text{W}$$

The above power limit is valid up to 60°C ambient temperature and should be derated by -5%/°C above 60°C ambient conditions, reducing by -50% at an ambient temperature of 70°C. Above this temperature limit, AVR will be stressed above its design capacity. If the ambient conditions of the AVR is suitable, the excitation power can be higher, provided that the given excitation current limits and the power input voltage limits values are not exceeded.

10.1.3: IDMT curve Protection for Excitation:

OEX protection function is based on IDMT curve fitting technique. This feature operates together with the OEX protection function and cannot be disabled. The “Excitation Current” into the FIELD winding is precisely calculated and fitted with the IDMT curve type “**IEC Standard Inverse Curve-A**”. With this method, DAVR40 precisely calculates the thermal load on the alternator winding and protects the winding and the drive stage of the AVR.

IDMT curve calculation is executed according to the formula given below:

$$x = T \cdot (k/(y/I) \propto -1)$$

The standard curves are shown below for reference and DAVR is fitted with the IEC (A) curve characteristics and cannot be changed or disabled by the user.

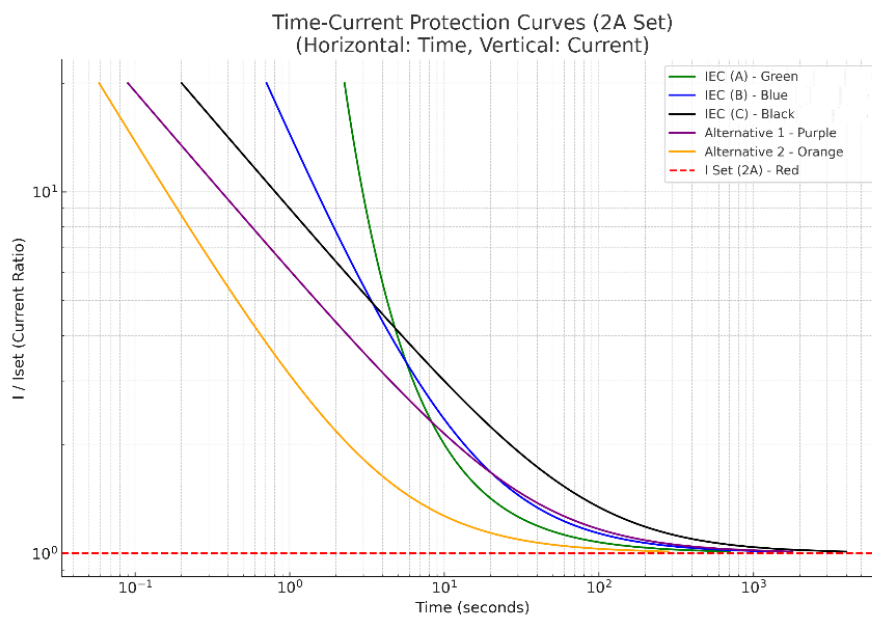

Line colour	Curve	T	k	\propto
Green	IEC Standard Inverse curve A	1	0.140	0.02
Blue	IEC very Inverse curve B	1	13.5	1
Black	IEC Extremely Inverse curve C	1	80	2
Purple	Alternative curve A	0.449	80	2
Orange	Alternative curve B	28.57	0.140	1.4142

Based on the EXCITATION current demand by the alternator, thermal model of the switching power stage of the AVR is continuously iterated and protection is activated based on the OEX parameter settings, which are described in more detailed in the protection functions section of this user manual. The IDMT curve calculation is based on the “OEX Threshold Current Limit” value set by the user. The maximum limit cannot be changed, and it is fixed in the firmware of the AVR control software.

10.2 Fuse protection:

DAVR40 has no “on-board” integrated protection fuses, and all required fuses MUST be fitted externally. External fuse protection must be selected according to the regional standards compliance requirements, and they are intentionally not fitted on to the AVR unit.

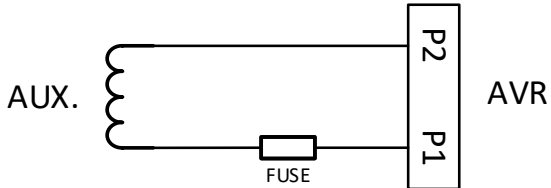
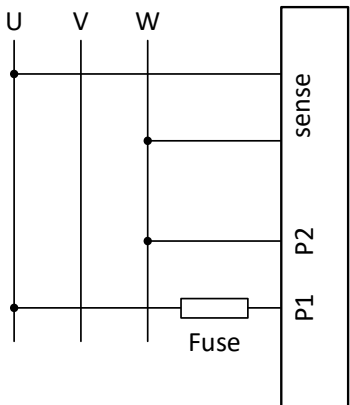
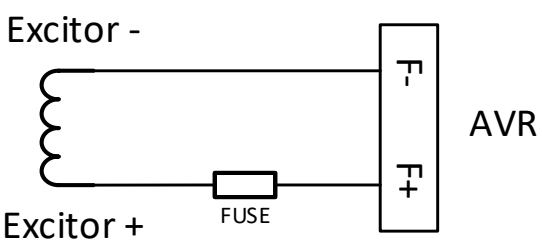
AVR FUSE rating (must be used externally)	FUSE connection schematics
<p>6,3A (quick blow type fuse) AUX winding connected protection</p>	
<p>6,3A (quick blow type fuse) SHUNT connected protection</p>	
<p>10A (quick blow type fuse) DC FIELD protection</p>	



To comply to UL safety standards, a suitable fuse protection is required in the cable harness. A suitable fuse protection MUST be used with DAVR40 in all applications. In some applications, it is also required to use a separate fuse for the sensing inputs, and this regulation must be checked and fulfilled by the user.

11- Setting the Protection functions on DAVR40:

DAVR40 is designed with flexible protection functions that the user can configure according to their application requirements. All parameters are set to their factory default values and it is recommended that the user checks all the protection functions and sets them to suit their application.

Protection functions can have the following actions to act upon the alarm condition, and the details are explained in the table below:

PROTECTION ALARM	Programmable Actions for each Alarm condition	Setting limits	Explanation:
OVER EXCITATION	<ol style="list-style-type: none"> 1. Trigger threshold 2. Trigger delay time 3. Relay trigger flag 4. Output trip flag 	Determined in the PCTools Software	All alarm states are explained in the related chapter of this user manual
LOSS OF SENSE			
GENERATOR OVER-VOLTAGE			
GENERATOR UNDER-VOLTAGE			
STATOR VOLTAGE UNBALANCE			
GENERATOR CURRENT LIMIT			
WINDING TEMPERATURE			
EXTERNAL POT DISCONNECT			
AVR TEMPERATURE			

11.1: “OEX Protection” function:

“Over-Excitation Protection” function monitors the excitation current magnitude and triggers an internal delay timer. If the OEX current magnitude stays above the trigger threshold level, the alarm will trigger after the delay time register reaches its set value. The function can be linked to activate the relay if set in the configuration menu. The function details are shown in the table below:

Parameter Number	Parameter Description	Units	Parameter Limits	Explanations:
[P400]	OEX Threshold	Amp.	0 - 5000 (Default is 5000)	
[P402]	OEX Delay time	Sec.	0 - 60	
[P406]	OEX RELAY activation	-	[P406] = 0	Relay is DISABLED
		-	[P406] = 1	Relay is ENABLED

As described above, DAVR40 allows two stage OEX protection for the alternator:

- IDMT curve protection (IDMT)
- Limit Activated Time Delay (LATD)

IDMT protection function calculates the “Thermal Load” on the “Excitation Winding” and the “AVR Power switching circuit”, based on “IDMT Curve Fitting” technique and cannot be disabled. “Time Integrated” thermal limit control is dominant and AVR will HALT excitation without any time delay, once this limit is reached. IDMT protection trip function automatically activates the relay before the AVR shuts down.

The control curve is based on “**IEC Standard Inverse Curve-A**” (graphic is shown above) and “OEX Threshold” value sets the nominal current value of the IDMT curve calculation and effects the TRIP characteristics of the protection function. Therefore, parameter **[P400]** must be set according to the specifications of the alternator. For other types of curve fitting, please contact the manufacturer.

Proper setting of “OEX Protection” function is crucial for a reliable operation and therefore, user needs to consider the limits of the “Excitor Winding” and the operational environmental conditions. “OEX Threshold” current value setting determines the maximum steady current magnitude of the IDMT function and therefore should be set according to the operating conditions of the alternator. The function is shown on figure below:

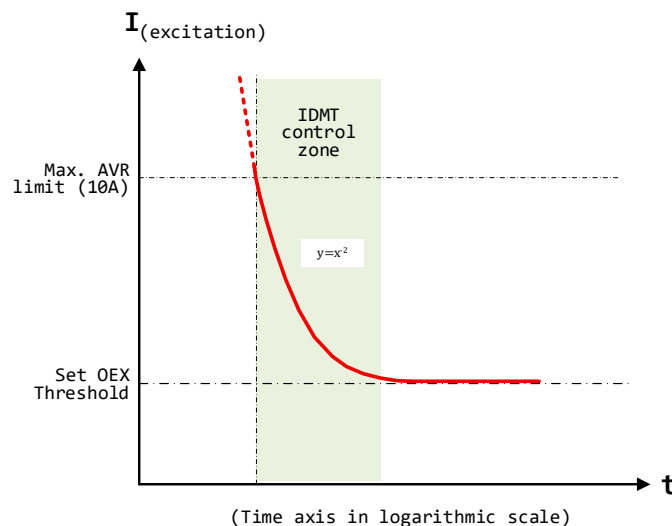

LADT protection is a second measure of protection, where the trip delay time can be set according to load characteristics of the alternator. If the operating conditions are adverse (bad ventilated locations, operating at elevated temperatures), user can set a second level of protection, based on the total time that the excitation exceeds “OEX Threshold” level. The “DELAY Time” register is automatically RESET back to ZERO every time the “Excitation Current” falls below the set “OEX threshold limit”, therefore protection characteristics is somewhat different than the IDMT model running in the background, which cannot be disabled.

If the TRIP state is reached due to high-current demand for a prolonged period, AVR Excitation and the RELAY will activate at the same time (if the RELAY parameter “[P406]” is set to “1”). In this case, relay contacts can be used as a secondary safety protection feature in case the AVR fails to regulate. If there is FAULT condition on the AVR Excitation stage (SCR short circuit and/or damaged), the RELAY action can be used to trip the power to the AVR so that the generator operation can be safely terminated.

Since DAVR40 can only be connected in AUX or SHUNT mode, the power to AVR will be lost as soon as the excitation drive stage switches off. Therefore, the relay activation will be a short duration, which is enough to trigger a secondary protection device to cut the power to AVR.

The IDMT protection function calculates the “Thermal Load” on the AVR heatsink and acts on the “OEX Threshold” parameter setting. Therefore, user MUST select the suitable AVR model with the appropriate EXCITATION DERIVE” capability, usually above the maximum EXCITATION current required by the alternator and set the “OEX Threshold” parameter accordingly.



If OEX protection is activated due to adverse operating conditions, the AVR will shut down, and excitation will stop. Since the thermal load on the windings and the AVR drive stage are calculated by the IDMT function, be aware that, AVR cannot track how long the generator cooled before it starts again. If the generator is switched on again before the windings are sufficiently cooled, the actual winding temperature may rise above the limits of the alternator and catastrophic failure can happen.

Therefore, after OEX Trip, ensure that the alternator is cooled down to its normal operating temperature levels so that, OEX Protection function will function within its safe limits.

11.2: Loss-Of-Sense (LOS) protection function:

If the AVR is connected in 3-phase sensing configuration, embedded software continuously controls the voltage difference between each phase voltage connected to the sense terminals U, V and W. If any of the phase voltages drops below a preset calculated value, AVR will consider this as a “Loss-of-Sense” fault and trigger an internal FAULT flag, and it will start to monitor the FAULT based on the configuration settings of the related parameters. If the “LoS Delay Time” is exceeded, the AVR will TRIP, and excitation will stop. The TRIP action is fixed and cannot be set by the user.

“Loss Of Sense” voltage difference is fixed internally as -20% in comparison to the set “RMS Phase Voltage” of the alternator. Function monitors the difference of each phase voltage from the set alternator RMS phase voltage level and triggers an ALARM flag, if any of the phase voltages falls below the set -20% level. LoS TRIP is activated after the “LoS Delay” time if configured to do so.

The “LoS Alarm” can also be linked with the RELAY action if the RELAY parameter is set. Function is explained in the table below:

Parameter Number	Parameter Description	Units	Parameter Limits	Graphical presentation:
[P418]	LOS DELAY parameter	Sec.	0 - 25 (Default is 5 seconds)	
[P422]	LOS RELAY activation	-	[P422] = 0	RELAY action is DISABLED
			[P422] = 1	RELAY action is ENABLED

Once the TRIP is activated, AVR will stop the excitation and generator will shut down. If RELAY action is ENABLED, the relay will activate before the AVR shuts down. Contact configuration of the relay can be configured by the user, by setting the related parameters from the menu.

11.3: Generator Over Voltage (GOV) protection function:

DAVR40 can control the alternator phase voltages to make sure that, generator voltage does not exceed a specific set value margin. This type of failure can be caused due to an internal failure of the AVR or type of load connected to the alternator.

If the function is configured correctly, it can trigger an ALARM condition or TRIP the AVR to stop excitation. The operation of the function is based on the calculation of 3-phase average voltage, compared to the “RMS Alternator Set Voltage” level and if the difference exceeds a certain margin (as configured by the user), alarm will automatically trigger after a delayed period.

The configuration of GOV function and its logical operation is explained in the table below:

Parameter Number	Parameter Description	Units	Parameter Limits	Graphical presentation:
[P425]	GOV percentage	%	0 - 50 (Default is 20%)	
[P426]	GOV DELAY time	Sec.	0 - 10 (default = 10 sec.)	DELAY time can be set up to 10 seconds.
[P430]	GOV RELAY activation	-	[P430] = 0	RELAY action is DISABLED
			[P430] = 1	RELAY action is ENABLED
[P431]	GOV trip activation	-	[P431] = 0	TRIP function is DISABLED
			[P431] = 1	TRIP function is ENABLED

[P425] is set as a percentage of the set RMS alternator voltage. If for example, the set AVR regulation voltage level is 400Vac, then setting [P425] = 20 means that, AVR will trigger an internal alarm flag if the voltage exceeds 20% of 400Vac, which is 440Vac. Once this set threshold is exceeded, an internal GOV Delay timer will start timing. If the voltage falls below the “GOV Threshold Limit” value before the “GOV Delay Time” period, the flag is automatically RESET, and the timer also resets to zero.

If TRIP is enabled, AVR will switch off the excitation drive and stop completely. If ALARM relay is activated and TRIP is disabled, only the relay will be energized to send an external signal and AVR will continue its normal operation.

11.4: Generator Under Voltage (GUV) protection function:

DAVR40 monitors the alternator voltage and set an alarm action, if the voltage falls below set RMS alternator reference control level. Like GOV protection function, the AVR will compare the alternator voltage against configured “GUV Percentage” level and initiate an internal “GUV Delay Timer” before triggering any RELAY or TRIP function.

“GUV Percentage” is set as a percentage of the set AVR reference voltage value. If for example “GUV Threshold Level” is set to 20%, then the Under Voltage Threshold level will be 360Vac and AVR will control the protection function against this value.

Falling below the “GUV Percentage” value, an internal FLAG will be set and after the delay time, either a TRIP protection or a RELAY activation will trigger.

Function parameter settings and operation is explained on more detail in the table below:

Parameter Number	Parameter Description	Units	Parameter Limits	Graphical presentation:
[P433]	GUV percentage	%	0 - 50 (Default is 20%)	
[P434]	GUV DELAY time	Sec.	0 - 10 (default = 10 sec.)	DELAY time can be set up to 10 seconds.
[P438]	GUV RELAY activation	-	[P438] = 0 [P438] = 1	RELAY action is DISABLED RELAY action is ENABLED
[P439]	GUV trip activation	-	[P439] = 0 [P439] = 1	TRIP function is DISABLED TRIP function is ENABLED

If the generator voltage rises above during “GUV Threshold” level during “GUV Delay Timer” period, the timer resets its count and will stay in reset condition until the next limit violation.

11.5: Stator Voltage Unbalance (SVU) Protection:

DAVR40 monitors the alternator STATOR voltage unbalance level and protection can be activated if configured on the AVR unit.

Stator Unbalance function monitors each phase voltage of the alternator against the “Average” value of the 3 phases. If the measured unbalance value exceeds a predetermined level, AVR sets an internal FLAG to start the protection function activation.

An internal “SVU Delay” timer starts counting to time the duration of how long the unbalance value is exceeded. If this duration exceeds the set timing limit, RELAY or TRIP action will initiate according to the function parameter configuration.

Parameter Number	Parameter Description	Units	Parameter Limits	Graphical presentation:
[P441]	SVU percentage	%	0 - 50 (Default is 20%)	
[P442]	SVU DELAY time	Sec.	0 - 30 (default = 10 sec.)	DELAY time can be set up to 10 seconds.
[P446]	SVU RELAY activation	-	[P446] = 0	RELAY action is DISABLED
			[P446] = 1	RELAY action is ENABLED
[P447]	SVU trip activation	-	[P447] = 0	TRIP function is DISABLED
			[P447] = 1	TRIP function is ENABLED

If the measured “SVU” value falls below the set threshold level before the Delay timing is ended, the timer will automatically reset to zero and start counting again from the instant of violation of the SVU set threshold level. At the end of the timed duration, protection function will either trigger a RELAY action or a TRIP action, which stops the AVR excitation.

11.6: Generator Current Limit (GCL) protection Function:

It is possible to limit the alternator stator current according to application requirements. In this case, if the GCL limit is reached, it is possible to limit the load current, hence the voltage will vary according to the load current demand. The stator current is measured across CT terminals connected to the AVR.

Stator current is measured only from “V” phase of the alternator, and it is considered that the load is balanced, and same current magnitude is flowing from “U” phase and the “W” phase of the alternator. With slightly unbalanced loads, this method may introduce slight error, but this can be ignored for GCL function execution.

Parameter Number	Parameter Description	Units	Parameter Limits	Graphical presentation:
[P448]	GCL Threshold	%	0 - 300 (Default is 300%)	
[P450]	GCL DELAY time	Sec.	0 - 32 (default is 10 sec.)	DELAY time can be set up to 32 seconds.
[P454]	GCL RELAY activation	-	[P454] = 0	RELAY action is DISABLED
			[P454] = 1	RELAY action is ENABLED
[P455]	GCL TRIP activation	-	[P455] = 0	TRIP function is DISABLED
			[P455] = 1	TRIP function is ENABLED

The GCL protection function is always active in the system and cannot be terminated. This function sets a flag in the alarm log registers of the AVR each time the threshold limit is exceeded. User can only select if this function should activate an alarm relay contact or trip the AVR operation, when the limit is exceeded for the programmed time duration.

If the load current falls below “GCL Threshold” level during “GCL Delay Time” period, the timer is automatically reset and starts counting again if the limit is exceeded.

11.7: Winding Temperature Alarm (WTA) function:

DAVR40 is equipped with a temperature measuring channel, T1-T2, where only RTD type temperature sensors can be used. It is preferred to use Pt100 type temperature sensors for the windings with the proper sensor type selected for any specific application, considering the potential insulation barrier for the sensor connection.

With the correct sensor connected to the AUX terminals (T1, T2) on the AVR unit, user is expected to configure the parameters for this function according to the table as shown below, considering the interaction behaviour of WTA function together with WTL function.

Parameter Number	Parameter Description	Units	Parameter Limits	Graphical presentation:
[P456]	WTA Threshold	°C	40 - 200 (Default is 200%)	
[P458]	WTA DELAY time	Sec.	0 - 15 (default = 10 sec.)	DELAY time can be set up to 15 seconds.
[P459]	WTA activation ENABLE	-	[P459] = 0	WTA action is DISABLED
			[P459] = 1	WTA action is ENABLED

In DAVR40, measuring the winding temperature has flexible parameters so that the user can protect the winding under safe limits and at the same time allow momentary high-temperature peaks without jeopardising the alternator safety.

Therefore, “Winding Temperature Alarm” and “Winding Temperature Limit” actions are organised as two independent protection functions and can be configured according to application requirements. WTA protection function controls the ALARM RELAY and the WTL protection function controls the AVR TRIP action.

WTA temperature limit is 200°C maximum and can be set with an accuracy of ±1°C. There is no built-in hysteresis as the timer is designed to RESET as soon as the temperature falls below the threshold limit value. Timer starts to count as soon as the measured temperature level exceeds the limit value. If the winding temperature stays above the threshold limit for the duration of the DELAY time, RELAY will activate automatically but the AVR continues to regulate the stator voltage.

WTA function can be ENABLED or DISABLED according to application requirements. If the user has allocated the RELAY action for another protection function, P459 can be set to “0” to disable the RELAY activation.

11.8: Winding Temperature Limit (WTL) protection function:

DAVR40 has an additional secondary temperature protection function, named as “Winding Temperature Limit” protection function (WTL). This function acts as a secondary temperature protection feature, which has a higher temperature setting limit. In some applications, user can set WTA protection function to generate an ALARM RELAY contact to take necessary precautions (like load shedding or operating forced cooling systems) and if the temperature rise persists, WTL function can act as a TRIP protection for the AVR to shut off the excitation drive completely.

In some applications, this feature gives the user a “Fail-Safe” protection of the FIELD winding and/or the winding where the temperature sensor is located. In some applications more than one winding temperature can be measured with similar characteristics on each measuring channel. The function details are shown in the table below:

Parameter Number	Parameter Description	Units	Parameter Limits	Graphical presentation:
[P464]	WTL Threshold	°C	40 - 300 (Default is 250%)	
[P466]	WTL DELAY time	Sec.	0 - 15 (default = 10 sec.)	DELAY time can be set up to 15 seconds.
[P467]	WTL activation ENABLE	-	[P467] = 0	WTL action is DISABLED
			[P467] = 1	WTL action is ENABLED

If the WTL temperature level is reached, a second timer is activated and starts to count the WTL delay time. If the temperature stays above the WTL limit value for the delay period, TRIP action will be activated automatically and the AVR will STOP the excitation and system will shut down. WTL only acts on the TRIP function and cannot operate the RELAY.

The combined configuration of WTA and WTL protection functions can safely protect the alternator against abnormal operating conditions. WTL temperature value should always be set higher than the WTA temperature limit value so that, safe and consistent protection of the alternator windings can be achieved.

An example of the AVR behaviour with cascaded temperature protection setup is shown in the graphical representation below:

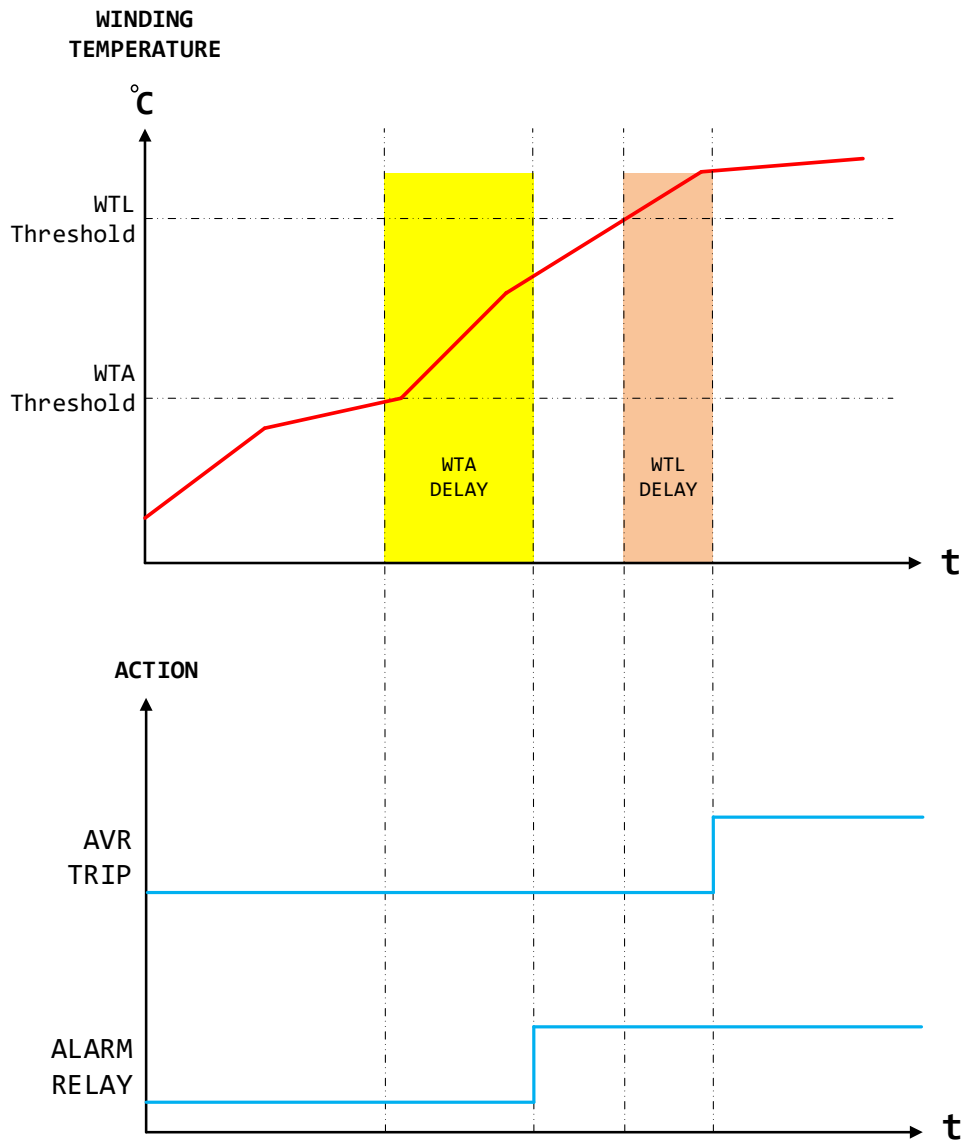

The WTA and WTL functions operate on the same temperature input sensor value connected to T1-T2 terminals of the AVR unit. It is practical to set the WTL above WTA limit, to protect the alternator winding within the safe limits and at the same time, get the best power handling performance from the generator system.

11.9: Alternator “Short Circuit” Threshold:

DAVR40 can supply sustained Excitation current to the FIELD winding of the alternator to maintain overload conditions during sudden high-load application to the generator. Based on the selected parameter settings, DAVR40 calculates the set % PU magnitude and measures the stator load to maintain excitation current for the excitor during high-load application to the generator.

To be able to supply the required excitation power to the alternator, parameter [P121] must be set according to application scenario and any stator current measured above this “Threshold Current Limit” will be considered as momentary “Short- Circuit” and the AVR will carry on supplying Excitation power to the alternator for a certain (programmed) period. During this operation, AVR protection functions like LoS, GCL and GUV protections will be disabled. Function description and parameter settings are explained in the table below:

Parameter number	Parameter Description	Units	Parameter set limits	Explanations:
[P121]	AVR “SHORT CIRCUIT THRESHOLD” limit	mA	1000 - 15000 (integer value)	Sets the “short circuit” limit on the AVR as measured CT current value (based on PU calculation)

Setting “[P121]” is particularly critical if the alternator is going to deliver sustained short circuit power into the excitation winding when the alternator is momentarily subjected to “high load”, like starting a high-power induction motor. In this case, since power is required to the excitor under high-load conditions, the power to AVR must be supplied from an AUXILIARLY power winding. SHUNT connection in this case may have poor performance as the stator voltage is also expected to dip during sudden high-load application.

“P121] is set according to the PU ampere value of the CT on the alternator. Therefore, if the CT current ratio is X/5 on the alternator, then set P121 = 7500 which corresponds to 1.5PU of the stator load current. In this case, the AVR will consider that alternator is under short circuit conditions if the measured current exceeds 1.5PU value and keep maintaining the excitation current to the excitor winding for a programmed time duration.

The PU value of the alternator is defined with the parameter number [P135], which sets the “CT Transfer Ratio” of the AVR. 1 PU of the alternator is the full-scale current value set by the CT Transfer Ratio parameter and the mathematical calculations are based on this set value.

11.10: Setting the RELAY operation mode:

The “Alarm” relay on DAVR40 has a SPST dry contact output and can be triggered if any of the selected alarm is in the “TRUE” state. Linking the alarm relay to any one of the alarm conditions monitored and detected within the AVR is set in the PC-Tools Software menu. The RELAY normal position (when there is no TRUE alarm condition) can be set from the configuration menu according to the table below:

Parameter Number	Parameter Description	Units	Parameter Limits	Explanations:
[P150]	RELAY normal position	-	0 = N/O 1 = N/C	If set to “0”, then the relay is “de-energized” if there is no TRUE alarm condition, If set to “1”, then the relay is “energized” if there is no TRUE alarm condition,

11.11: Alarm FLAGS and Alarm output RESET:

If an ALARM condition occurs on DAVR40, the alarm flags register will set and latch, and the AVR unit will remember which alarm has triggered the alarm condition. Users can connect via the onboard USB bus and view all the alarm list in the order of occurrence.

The ALARM log in the memory location is arranged as a FIFO type storage, and the depth is up to 64 alarms. As soon as the ALARM log memory is full, the next alarm that occurs will be written over the oldest alarm flag and the log moves down as the new alarms occur. There is also a pointer INDEX which indicates the oldest alarm register position so that the users can follow the list in the correct order.

If the user wants to clear the current alarm trigger state, parameter “P103” can be used to RESET the current alarm condition. If the ALARM condition no longer exists, setting this parameter to “0” will clear the output. If the alarm condition still exists, the flag will set again automatically.

Parameter Number	Parameter Description	Setting limits	Explanations:
[P103]	Clear Output Errors	0	Clear all internal ERROR flags
		1	Internal ERROR flag is activated

11.12: Alarm LED Indication:

DAVR40 is built with an ALARM and STATUS LED indicator on the unit, and it is an RGB LED. Operation status indication is explained below:

STATUS	LED Indication:	Explanations:
AVR operating	GREEN, continuous	AVR is operating under normal conditions, no alarms
AVR Fault Condition	RED, continuous	There is an ALARM condition
USB Communication	BLUE, flashing	USB communication is normal, BLUE LED flashing if port is connected and communicating

If there is an ALARM condition and the AVR is shut down due to the alarm condition, user can connect with PC-Tools SW package to check what alarm caused the system to shut down. User can clear the alarm FLAGS before starting the AVR again, but this is not necessary. During the next start-up sequence, the AVR will give a RED alarm indication and then go back to normal operating condition, if the alarm condition is removed. If the alarm condition is still persistent, AVR will shut down again and register the cause of the failure in its alarm log memory.

11.13: Resetting parameter settings:

If the user wants to set the parameters back to “Factory Default” setting values, it is possible to do so by setting parameter [P203] to “1” and this action will reset all the AVR parameters back to factory default values. Utilisation of this parameter is shown in the table below:

Parameter	Parameter setting range:	Explanations:
[P203]	0	Flag is set to “0” automatically if any of the parameters are changed by the user.
	1	If [P203] is set to “1” via PC Tools S/W, all the parameters are forced to “Factory Default” values.

11.14: Reset internal engine hours meter:

DAVR40 has an integrated clock (not a real time clock) which keeps the time while the AVR has power across its P1 and P2 terminals. Therefore, this internal timing register keeps an approximate value of AVR working hours, which also roughly corresponds to engine working hours value.

If there is an alarm detected by the AVR, the alarm log stores the alarm type, stamped with its internal timer register value. When the alarm/event log is reached by the user via PC Tools S/W, it is possible to see the time of alarm/event condition activated with respect to this internal timing register. If user wants to reset this timing register, parameter [P204] can be used. Operation is explained in the table below:

Parameter	Parameter setting range:	Explanations:
[P204]	0	Normal operating condition
	1	If [P204] is set to “1” via PC Tools S/W, the internal timing register is reset to “0000” and will start timing next time the AVR is energised.

12- Communication ports:

DAVR40 is equipped with a USB type-B com port for device configuration and also performance monitoring during system commissioning.

USB port is galvanically isolated from the power connection terminals group of the AVR unit. Therefore, the com port on DAVR40 can be used safely while the generator is running,

All AUXILIARY terminals and the USB COM port are galvanically connected to the same isolated power supply; therefore, it must be observed that, COM ports and the AUXILIARY terminals are all floating on the same potential, isolated from the alternator power side.

USB port is designed for device configuration and at the same time, PC-Tools software package can run during AVR commissioning to monitor the alternator behaviour on the PC screen, using oscilloscope tools of the configuration software package.

12.1: Connection to USB port:

To configure the AVR, it is required to connect to the USB port and use PC-Tool Software package to reach all the configurable parameters in the AVR unit.

Use a printer cable (type-B) to connect to the AVR unit. Make sure to use a new cable for reliable operation. The unit receives its own power to feed its microcontroller circuit inside the AVR, therefore, when connected via USB port, no external power is required for the AVR configuration.

Once connected and secured, it is possible to read all the current parameter data from the AVR and at the same time, carry out all necessary parameter settings and saving them back in the AVR memory. It is also possible to check all the alarm logs and operating hours information and also, reset all alarm flags and clear internal error registers.

Parameter list is given at the end of this user manual. The parameter numbers do not follow in suit because the intermediate parameter numbers are hidden, and they are not available to the user. These parameters can only be set during manufacturing, and user cannot reach these parameters during configuration.

USB connection data is set in the PC-Tools software menu and passwords are controlled by this SW.

COMPORTS	COMPORT connections
<p>USB PORT CONNECTION (TYPE-B CABLE) (no external power is required)</p>	

12.2: Firmware ID registers:

DAVR40 has two additional registers where the device SW ID is stored. If FIRMWARE update is required from remote access point, it is required to know the “Internal Bootloader Version” number and at the same time, the remote-control software needs to read the existing Firmware version number. These data are stored in parameter addresses as shown in the table below:

Parameter Number:	Parameter Description	Setting limits	Explanations:
[P9975]	Current BOOTLOADER version number	<p>1000 - 32767 (Default setting = 1000)</p>	<p>Required if the FIRMWARE of the AVR is to be upgraded from a remote access point. These registers are “Read-Only” registers and cannot be changed.</p>
[P9976]	Current FIRMWARE version number	<p>1000 - 32767 (Default setting = 1000)</p>	

13- Application Diagrams:

DAVR40 can be connected to the alternator in various alternative ways, based on the application requirements. Some of the common wiring diagrams are given in the following topics but not limited with the given examples. For specific wiring requirements, please contact ENKO engineering team for further assistance.

13.1: DAVR40 installation with 3-phase sensing and AUX winding:

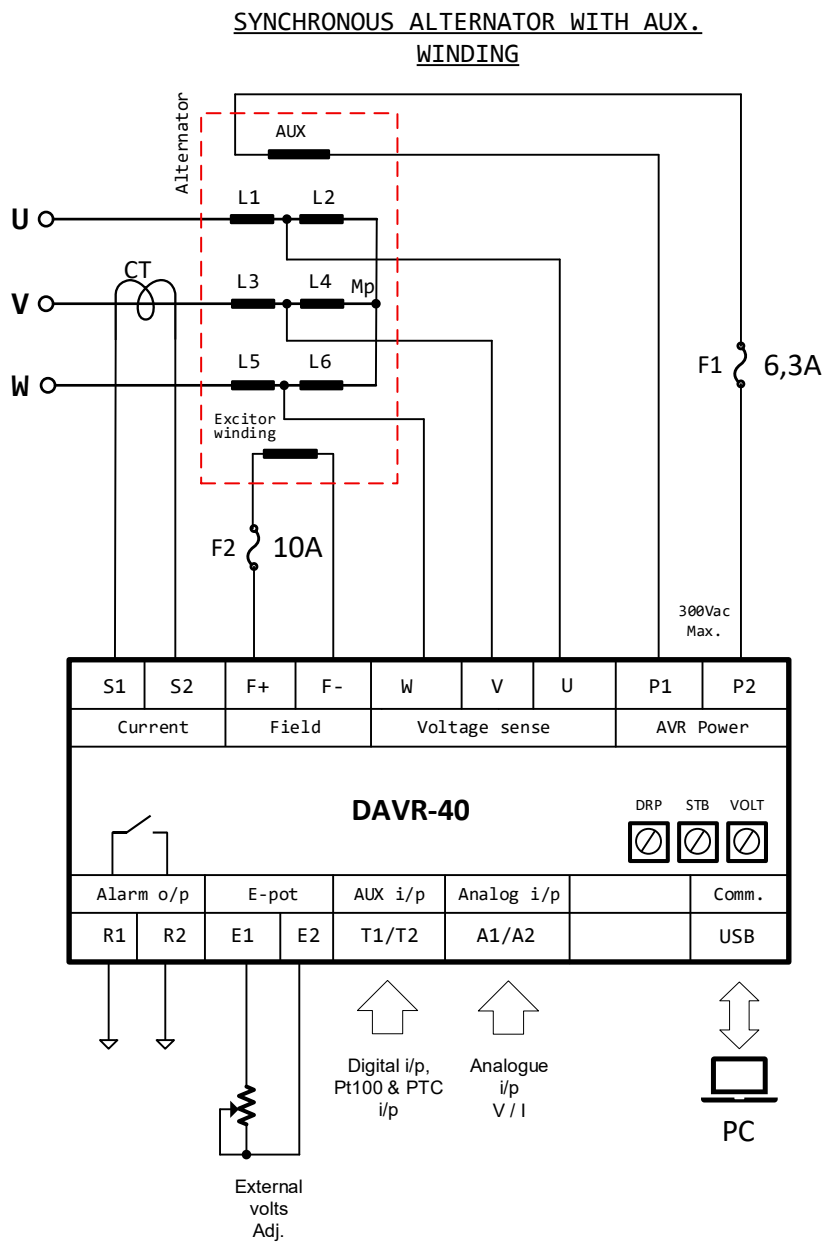

13.2 DAVR40 installation with SHUNT configuration:

SYNCHRONOUS ALTERNATOR WITH SHUNT CONNECTION

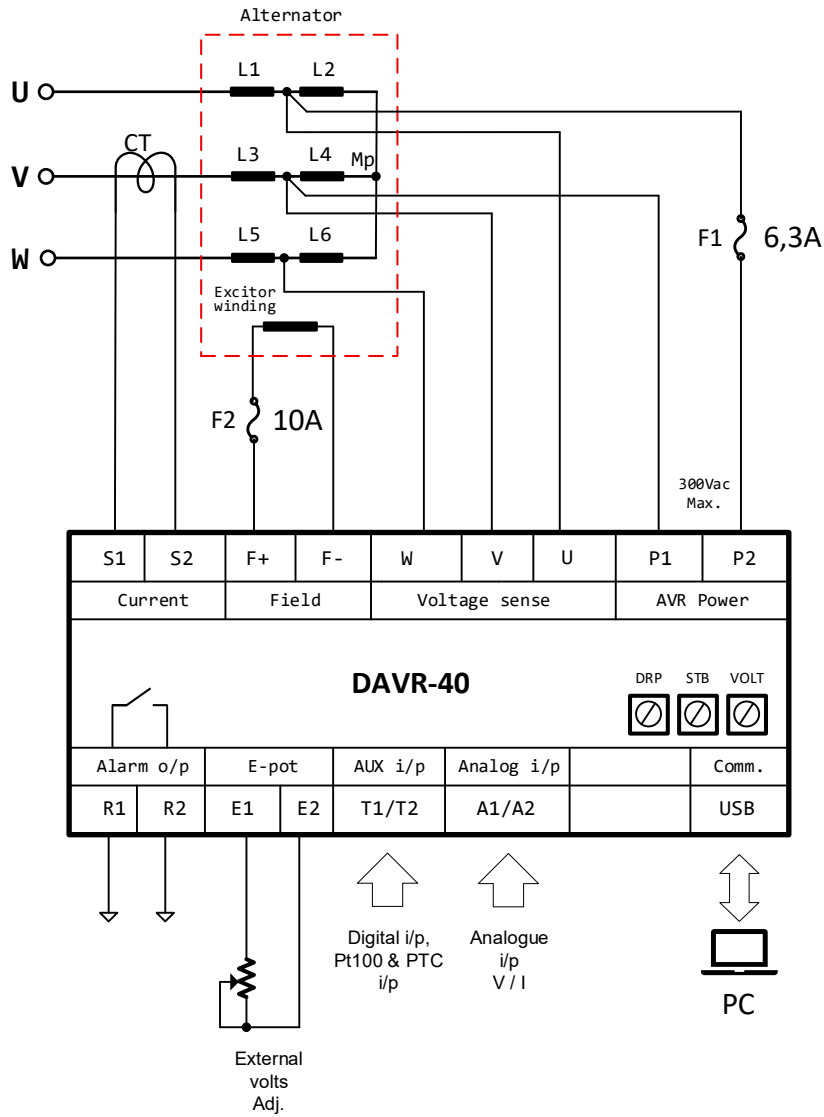



14- DAVR40 Parameter List:

14.1: “Read-Only” Parameters:

No:	Parameter:	Unit:	Min.	Max.	Default	Explanations:	Mask:	Effect:
P000	UV RMS Voltage	V	0	600	0	Phase - Phase RMS Voltage measurement		
P001	VW RMS Voltage	V	0	600	0	Phase - Phase RMS Voltage measurement		
P002	WU RMS Voltage	V	0	600	0	Phase - Phase RMS Voltage measurement		
P006	UV Frequency	Hz	0	80	0	Phase - Phase Frequency measurement		
P007	VW Frequency	Hz	0	80	0	Phase - Phase Frequency measurement		
P008	WU Frequency	Hz	0	80	0	Phase - Phase Frequency measurement		
P014	Field Current RMS	mA	0	10000	0	Field Current RMS measurement		
P020	DROOP Current RMS	% PU	0	100	0	DROOP Current RMS measurement by 1 PU		
P025	AUX Voltage Input Value	V	0	10	0	Auxiliary voltage input measurement		
P027	VOLTS Pot	%	0	100	0	VOLTS Trimmer measurement. Percentage of the effect on the output voltage		
P028	STAB Pot	%	0	100	0	STAB Trimmer measurement. Percentage of the effect on the PID parameters		
P029	DROOP Pot	%	0	100	0	DROOP Trimmer measurement. Percentage of the effect on the output voltage		
P033	EXT Pot	%	0	100	0	External pot measurement		
P034	EXT Pot Connected		0	1	0	External pot connection status flag. Reference voltage would stay same in case of broken pot. It will return to reference voltage on restart if there is no pot connected.	0: N/A 1: Connected	
P035	Controller State		0	6	0	AVR status	0: Pre Init 1: Init 2: Startup 3: Standby 4: Soft Start Delay 5: Soft Start 6: Normal Operation	
P037	Effective Reference Voltage	V	0	580	0	Actual voltage reference that is AVR trying to reach. In relation with Onboard VOLTS pot external pot UFRO LAM DROOP		- P100 - P25 - P26 - P27 - P29 - P33
P041	Calibration Ready		0	1	0	Calibration status parameter. Check 'Calibration Verification' parameter to verify		



P042	Configuration Ready		0	1	0	Configuration status parameter. Check 'Calibration Verification' parameter to verify		
P043	DAVR Ready		0	1	0	AVR is ready to operate no latched errors		
P044	USB		0	1	0	USB Connected		
P046	12V Ready		0	1	0			
P049	UFRO		0	1	0	UFRO function is ongoing. detected Low Frequency		
P050	SHORT CIRCUIT		0	1	0	Stator Current Measurement reached short circuit		
P051	RELAY		0	1	0	Alarm Relay Activated		
P052	OUT TRIP		0	1	0	AVR Output Cutoff		
P055	OEX		0	1	0	Over Excitation Protection Activated		
P057	LOS		0	1	0	Loss Of Sense Protection Activated		
P058	GOV		0	1	0	Generator Over Voltage Protection Activated		
P059	GUV		0	1	0	Generator Under Voltage Protection Activated		
P060	SVU		0	1	0	Stator Voltage Unbalance Protection Activated		
P061	GCL		0	1	0	Generator Current Limit Protection Activated		
P064	WTA		0	1	0	Winding Temperature Alarm Protection Activated		
P065	WTL		0	1	0	Winding Temperature Limit Protection Activated		
P093	Maximum Ambient Temp History	°C	0	85	0	Maximum ambient temperature of this AVR has ever exposed		
P094	Minutes	Min	0	59	0	Generator working time		
P095	Hours	Hr	0	23	0	Generator working time		
P096	Days	D	0	364	0	Generator working time		
P097	Weeks	Wk	0	51	0	Generator working time		
P098	Years	Yr	0	99	0	Generator working time		
P099	Centuries	C	0	99	0	Generator working time		

14.2: "Settable" Parameters List:

No:	Parameter:	Unit:	Min.	Max.	Default	Explanations:	Mask:	Effect:
P100	RMS Voltage Set	V	100	480	100	Nominal RMS Reference Voltage. Effected by UFRO LAM DROOP and Pots.		
P101	AVR Start		0	1	0	AVR's start status flag. Also, can be used to manually start AVR if there is no error.	0: Stop 1: Start	
P102	AVR Auto-start		0	1	0	AVR auto start setting. If enabled AVR will start as soon as there is no errors.	0: Disabled 1: Enabled	
P103	Clear Output Errors		0	1	0	Clear error flags setting. Note: flags will automatically turn on if error continues.	0: Disabled 1: Enabled	
P104	Start Delay	S	0	7200	0	AVR wait time in seconds while generator starting.		
P105	Start Frequency	Hz	25	75	25	AVR ramp up start frequency while generator starting. AVR will wait until sense frequency reaches this level.		
P106	Soft Start Time	S	1	7200	1	AVR ramp up time while generator starting.		
P107	Reference Change Ramp Limit Rate	V/S	1	100	50	Reference Voltage limit for not causing unstable reference while using pots etc.		
P109	Minimum Reference Percentage	%	1	100	75	Sets Minimum Reference setpoint limit percentage according to Reference RMS.		
P110	PID Kp		0	2048	425	Proportional coefficient of the controller. Increasing it will cause faster AVR reaction but worse steady state stability.		
P111	PID Ki		0	2048	250	Integral coefficient of the controller. Increasing it will cause better steady state stability but worse reaction time.		
P112	PID Kd		0	2048	125	Derivative coefficient of the controller. Increasing it will cause faster AVR reaction but worse steady state stability.		
P117	UFRO Knee Point	Hz	40	65	48	This point will determine at what frequency AVR starts derating output voltage. It is used while taking block load.		
P118	DIP Rate	V/Hz	0	80	8	This rate will determine how much drop will be applied to output voltage. It is used while taking block load.		
P119	DWELL Time	V/S	0	480	0	This rate will determine how fast should output voltage recover after derating. Increasing it will cause faster recover time.		
P120	LAM Mode Selection		0	1	1	Selection of the recover after derating mode. Should be changed according to block load performance of the system.	0: NORMAL 1: ENHANCED	
P121	Short Circuit Threshold	mA	1000	15000	4200	Short Circuit Mode Threshold. AVR will get into the short circuit supply mode after this threshold. Attention! This Mode will disable LOS GCL and GUV. Disables after Droop Current drops below threshold.		



No:	Parameter:	Unit:	Min.	Max.	Default	Explanations:	Mask:	Effect:
P122	Sensing Mode		0	7	1		0: N / A 1: U - V 2: V - W 4: W - U 7: U - V - W	
P123	AUX Input Mode		0	3	0	Auxiliary input mode selection. AUX input will affect output voltage. In case of external pot connection this input should be disabled.	0: Disabled 1: - 5 / + 5V 2: 4 - 20mA 3: 0V - 10V	
P124	AUX Input Range	%	0	100	30	Auxiliary input's effect range on output voltage		
P135	Current Transfer Ratio	A	0	1024	1	Current transfer ratio This ratio determines 1PU DROOP current.	205: X / 5 1024: X / 1	
P137	DROOP Mode		0	3	0	DROOP function determines stator current's effect on output reference voltage.	0: Disabled 1: Line DROOP 2: Load Balance 3: Quadrature	
P138	DROOP Phase Compensation	°	0	1200	600	DROOP current phase compensation. Needed if there is phase shift between current and voltage.		
P139	VOLTS Trimmer Effective Range	%	0	30	30	VOLTS trimmer effective range on output voltage.		
P140	STAB Trimmer Effective Range	%	0	30	30	STAB trimmer effective range on controller parameters.		
P141	DROOP Trimmer Effective Range	%	0	10	6	DROOP trimmer effective range on output voltage.		
P142	External Pot Effective Range	%	0	30	30	External pot effective range on output voltage.		
P150	Relay Normal Position		0	1	0	Determines relay status while there are no errors	0: Normally Open 1: Normally Closed	
P203	Reset Parameters To Defaults		0	1	0	Reset all parameters to their defaults.	0: - 1: Reset	
P204	Reset Engine Hours		0	1	0		0: - 1: Reset	



No:	Parameter:	Unit:	Min.	Max.	Default	Explanations:	Mask:	Effect:
P270	ADT A Input Mode		0	5	0	ADT A input type selection. This parameter also effects related protections to selected type.	0: Disabled 1: Analog 2: Digital 3: Winding Temp 4: Aux Temp 5: External Start 6: External Stop	
P271	ADT A Temperature	°C	0	255	0	Temperature value of the ADT A input.		
P272	ADT A Value		0	255	0	This value could be Analog Digital Temperature according to input type selection.		
P400	OEX Threshold	mA	0	5000	5000	Over Excitation Trigger Threshold		
P402	OEX Delay	S	0	60	10	Over Excitation Delay Time		
P406	OEX Relay		0	1	1	Over Excitation Error Relay Trigger Flag	0: Disabled 1: Enabled	
P418	LOS Delay	S	0	25	5	Loss Of Sense Delay Time		
P422	LOS Relay		0	1	1	Loss Of Sense Error Relay Trigger Flag	0: Disabled 1: Enabled	
P425	GOV Percentage	%	0	50	20	Generator Over Voltage Trigger Level		
P426	GOV Delay	S	0	10	10	Generator Over Voltage Delay Time		
P430	GOV Relay		0	1	1	Generator Over Voltage Relay Trigger Flag	0: Disabled 1: Enabled	
P431	GOV Trip		0	1	1	Generator Over Voltage Output Trip Flag	0: Disabled 1: Enabled	
P433	GUV Percentage	%	0	50	0	Generator Under Voltage Trigger Level		
P434	GUV Delay	S	0	10	10	Generator Under Voltage Delay Time		
P438	GUV Relay		0	1	1	Generator Under Voltage Relay Trigger Flag	0: Disabled 1: Enabled	
P439	GUV Trip		0	1	1	Generator Under Voltage Output Trip Flag	0: Disabled 1: Enabled	
P441	SVU Percentage	%	0	50	20	Stator Voltage Unbalance Trigger Level		
P442	SVU Delay	S	0	30	10	Stator Voltage Unbalance Delay Time		
P446	SVU Relay		0	1	1	Stator Voltage Unbalance Relay Trigger Flag	0: Disabled 1: Enabled	
P447	SVU Trip		0	1	1	Stator Voltage Unbalance Output Trip Flag	0: Disabled 1: Enabled	
P448	GCL Threshold	%	0	3	3	Generator Current Limit Trigger Level		
P450	GCL Delay		0	32	10	Generator Current Limit Delay Time		



No:	Parameter:	Unit:	Min.	Max.	Default	Explanations:	Mask:	Effect:
P454	GCL Relay		0	1	1		0: Disabled 1: Enabled	
P455	GCL Trip		0	1	1	Generator Current Limit Masking on Startup Flag	0: Disabled 1: Enabled	
P456	WTA Threshold	°C	40	200	200	Winding Temperature Alarm Trigger Level		
P458	WTA Delay	S	0	15	10	Winding Temperature Alarm Delay Time		
P459	WTA Enable		0	1	0	Winding Temperature Alarm Enable Flag	0: Disabled 1: Enabled	
P464	WTL Threshold	°C	40	300	250	Winding Temperature Limit Trigger Level		
P466	WTL Delay	S	0	15	10	Winding Temperature Limit Delay Time		
P467	WTL Enable		0	1	0	Winding Temperature Limit Enable Flag	0: Disabled 1: Enabled	
P9975	Device BL Version		1000	9999	1000	Current bootloader version of the AVR.		
P9976	Device SW Version		1000	9999	1000	Current software version of the AVR.		



15- Basic Trouble shooting steps:

If the AVR is connected and the generator does not perform according to specified performance, then there may be problems either with the installation or the AVR settings parameter configuration may be set incorrectly. In this case, following steps can be applied to fix some of the major possible problems with the system.

15.1 AVR is connected and there is no voltage at the alternator output:

Troubleshooting: No Voltage Generation on Alternator Stator Terminals

If the AVR is connected to an alternator and fails to generate voltage at the stator terminals during start-up, follow these steps to diagnose and resolve the issue:

1. **Verify AVR Installation:** Ensure the AVR is properly installed and wired according to the instructions in this manual. Confirm that all connections are secure and that wires are correctly routed.
2. **Check Field Winding and Wiring:** Using a multimeter, verify that the alternator's field winding is intact and displays the correct impedance (Ω) as specified by the manufacturer. Also, confirm that the field wiring polarity is correctly matched on the AVR.
3. **Measure Residual Voltage:** Disconnect the P1 and P2 terminals from the AVR, run the generator, and check the residual voltage across these wires. It should be at least 6Vac RMS. If this voltage is absent, flash the field using a 9V DC battery to restore residual voltage above 6Vac RMS, then reconnect the terminals and restart the generator.
4. **Inspect Rotor Diodes:** Ensure that all rotor diodes are functioning correctly and are not faulty.
5. **Review Configuration Parameters:** Confirm that the AVR start control parameters are correctly set and that no conflicts exist in the start-up sequence.
6. **Examine Wiring Harness:** Check for any faults, loose connections, or damage in the wiring harness leading to and from the AVR unit.

By following these steps, you can systematically troubleshoot and resolve issues preventing voltage generation.

15.2 Voltage is generated but voltage reading is not correct:

Troubleshooting: Incorrect Voltage Reading Under Normal Running Conditions

If the alternator is not generating the correct voltage under normal operating conditions, follow these steps to identify and resolve the issue:

1. **Verify Voltage Range Selection:** Ensure that the "voltage range selection" is correctly set according to the wiring configuration.
2. **Check the VLT Pot Setting:** Confirm that the required voltage value can be properly set when the VLT pot is positioned near the middle.
3. **Ensure Correct Engine Speed & UFRO Knee Parameter:** Check that the engine is running at the correct speed and that the UFRO Knee parameter is properly set.
4. **Inspect Excitor Winding & Field Current:** When the generator is running under no-load conditions, verify that the field current is close to the calculated value. Also, check for any faulty wiring connections.
5. **Examine Rotor Diodes:** Ensure that all rotor diodes are in good working condition and functioning properly.

15.3 Voltage stability issues:

Troubleshooting: Stability Issues During Operation

If the generator experiences stability problems, follow these steps to diagnose and resolve the issue:

1. **Verify Engine Speed:** Run the generator under no-load conditions and ensure that the engine maintains a stable speed without fluctuations. If speed variations occur, check the engine governor settings to stabilize the speed.
2. **Adjust the STB Potentiometer:** Begin with the STB pot in the counterclockwise (CCW) position, then slowly turn it clockwise (CW) until voltage fluctuations stop. If stability cannot be achieved across the full range, review the PID parameters and ensure the STB pot is set correctly according to the user manual.
3. **Inspect Excitor Winding and Wiring:** Verify proper excitor winding installation and ensure AVR terminals are wired correctly. Also, check that voltage sensing parameters are properly configured.
4. **Examine Rotor Diodes:** Ensure that all rotor diodes are functioning correctly and are not faulty.
5. **Confirm Stable Operation Under Load:** Once voltage stability is achieved, verify that the generator operates as expected under load conditions. Additionally, check the dynamic response during load-on and load-off transitions to ensure performance remains within specified limits.
6. **Check Field Winding Power Supply:** If the issue persists, evaluate the field winding power requirements and review how the AVR unit is wired via P1 and P2 terminals. If the field current is too low at no-load conditions, refer to this manual to verify if P1 and P2 are connected across stator phase-phase midpoints (SHUNT mode). If so, reconfigure the wiring by connecting P1 to the phase midpoint and P2 to the neutral line. Run the generator at both no-load and full-load conditions to confirm proper excitation power supply to the excitor.

ENKO KONTROL SISTEMLERİ A.Ş.

(DAVR40 USER MAUNAL, 76 PAGES IN TOTAL)
(UPDATED 210/010/2025, REVISION 08)